

leolux

Collection 2025—2026



Contents

2	Discover Leolux	132	Tables
4	Leolux Experience Center Breukelen	134	Overview tables
6	Masters in form and function	136	BRAM
8	Craftsmanship and innovation	138	Canopy
10	For a more sustainable world	140	Dice
11	The click between you and Leolux	142	Elli
12	Leolux Visitor Center	144	Klaar
14	Yabu Pushelberg	146	Liliom
16	Sen, a play of depth and movement	148	Nunos
		150	Portello
		152	Prismo
20	Sofas	154	Tampa
22	Overview sofas	156	Toveri
24	Bellice	158	Bondi
28	Bora Balanza	160	Columna
30	Bora Bora / Bora Bèta	162	Conka
32	Devon	164	Taival
34	Enna	166	Tico
38	Felizia	168	Toveri Dining
40	Flint		
44	Horatio	170	Accessories
46	Loya	172	Overzicht accessoires
52	Lunetta	174	Cosy Cushions
56	Mayon	175	Cushion Lusso
58	Modius	176	Amund
64	Naila	178	Bolmin
68	Pulla	180	Foliage
72	Rego	182	Patio
76	Tango	184	Patna
		186	Valleys
78	Armchairs		
80	Overview armchairs	188	Overview footstools
82	Anton		
84	Caruzzo	192	Product information
88	Cream	194	Index
92	Kikko	195	Icons
94	Kudo	196	Your Leolux in the best condition
96	Lodey	196	Service and warranty
98	Lloyd	230	Materials
99	Mayuro	244	Leolux Centers
100	Pallone		
102	Papageno		
106	Parabolica		
108	Scylla		
110	Sen		
112	Chairs		
114	Overview chairs		
116	Baani		
118	Callas		
120	Caron		
122	Gyon		
124	Mara		
126	Mime		
128	Tamarinde		
130	Vynn		

Every Leolux is born from an interplay of individuality and craftsmanship. With your wishes for comfort, colours and materials, you determine how our craftsmen apply their expertise. In this way, every piece of Leolux furniture is made entirely to order.

This working method has nothing but advantages. First and foremost for you, of course, as the owner of beautiful personal design furniture. But also for all of us, as no unnecessary materials are used. And the materials we do use are of such high quality that your furniture guarantees years of living pleasure.

We invite you not to make any compromises when choosing your new furniture. The design, comfort and quality are a given; the look and materials are entirely up to you. So let your inspiration run wild. Explore and shape your living dream. Our professionals can't wait to get to work for you.

Discover Leolux

Leolux Experience Center Breukelen



There's no better place to discover the world of Leolux than the Leolux Experience Center in Breukelen, just off the A2 motorway between Utrecht and Amsterdam. This striking gold-coloured building is a cornucopia of design inspiration – but that's not all there is to see.



You're welcome to spend as long as you like in our new showroom, completed in late 2022 by our art directors and styling department. You can see and try all our designs, and decide which is right for you.

Expert advice

You can rely on our advisors to tell you exactly what the possibilities are, and explain the unique ways to combine items from our collection. If you'd like to make an appointment and get detailed advice, it's a good idea to bring photos, a

floorplan, and samples from your existing interior so we can tailor our recommendations to your needs.

A voyage of discovery

The showroom at the Leolux Experience Center is impressive in itself, but there's lots more to experience. Our hospitality corner offers high-quality refreshments and conversation, and elsewhere in the building you can find out about our company's rich history and unrivalled expertise, and the different materials we use in our furniture.

Masters in form and function



Jan Armgardt



Beck Design



Gino Carollo



Axel Enthoven



Stefan Heiliger



kaschkasch



Studiopepe



Hugo de Ruiter



Frans Schrofer



Studio Truly Truly



Gerard Vollenbrock



Christian Werner



Hanne Willmann



Yabu Pushelberg

A Leolux piece of furniture always has character. Exuberant, restrained or a perfect balance of the two. To guarantee the originality and aesthetics of our collection, we work with renowned international designers. Visionaries who, like no other, are able to unite form and function in a design object with the sole aim of capturing the attention in your living room.

Product development

Every Leolux model starts as a design by one of our designers. The Product Development department at Leolux develops such a concept into a fully fledged product. The first step is to test all designs against numerous criteria, such as aesthetics, quality, comfort and character. The key question here is: is this a design that will appeal to existing and new Leolux fans?

If the design passes this stringent test, it's time for the next step: developing a digital 3D model. Based on this model, we build a prototype. And that's all done by hand, without work instructions or templates. These are produced later based on the prototype. That's why building such a first model is a special skill; a craft in which experience and invention go hand in hand.

The first prototype is just the beginning. The Leolux design team meets every week to discuss progress, with the designer also regularly joining the meeting. Together, they assess each evolution of the model for all kinds of features. From comfort and design to the mechanics and any additions in the programme. And they also look at producibility: can the furniture be produced well and efficiently in the factory? We use all that feedback to hone the model (sometimes literally) until it is perfect.





Craftsmanship and innovation

In Venlo, a stone's throw from the river Maas, Leolux has been producing the finest furniture for more than 90 years. In 2025, the trade is a fine blend of craftsmanship and high-end technology. Let's take a closer look at how craftsmanship and innovation come together in your new Leolux.

Craftsmanship

Construction

Craftsmanship prevails in the production of Leolux furniture. The frame construction is a good example of this. This is where our wood specialists assemble all the sawn parts into a strong, durable construction. And when the frame is ready, our colleagues in the pre-upholstery department get to work applying the foam. By combining different 'hardnesses' of foam, they create the unique Leolux comfort.

Upholstery

For the upholstery, you can choose from fabric, leather or a combination. Unlike fabric, leather has small natural imperfections. Our leather inspectors detect and mark them so that they do not end up on your furniture. The leather is then cut to size. In our workshop, all the loose fabric and leather pieces are assembled into a cover. Attractive decorative stitching is no problem.

The end product

Some parts, such as the base and armrests, get a nice, strong coat of paint or powder coating. This is done by our colleagues in our own paint shop. Together with the body and upholstery, these components are then sent to the upholstery workshop. It is here, in an interplay of strength and finesse, that your new Leolux is completed. The final stage in a fine chain of craftsmanship.

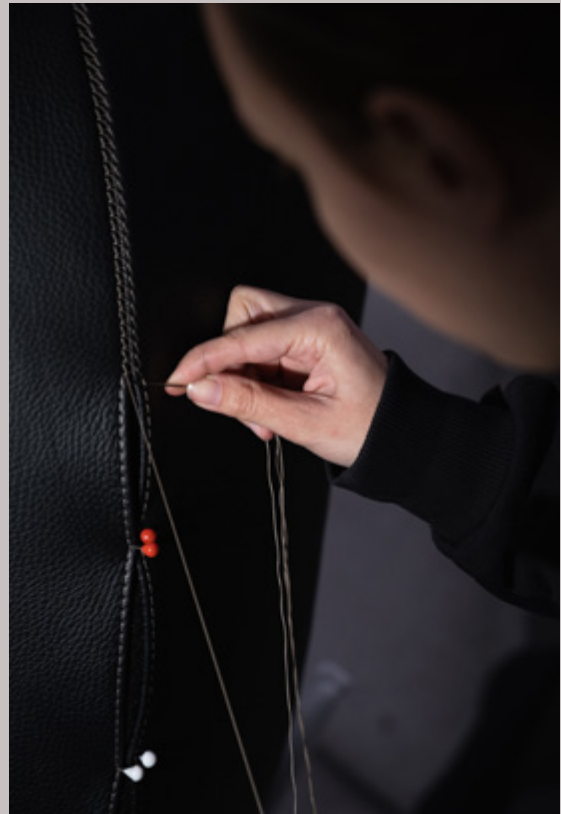

Innovation

Machined woodworking

In our brand new machined woodworking shop, all the wooden parts of the furniture body are cut to size, milled and pre-drilled. This is fully automated from the moment the timber is delivered. The warehouse stores the board material, manages the stock and delivers the sheets of plywood, MDF or OSB itself to the machine that cuts them to size. This machine calculates how to get as many parts as possible out of a board and switches between sawing, milling and drilling without any human intervention.

Cutting fabric and leather

We use high quality machinery to cut upholstery. The leather cutting machine takes into account the natural imperfections marked by our leather inspectors, as well as the shape of the hide. The fabric cutting machine has it a little easier as the fabric rolls are of a fixed size and quality. However, this machine still has to take into account the weave of the fabric and any patterns. Although our experts keep an eye on them, these machines work almost independently.

For a more sustainable world

Leolux makes products with a long lifespan. For us, that sustainable product is the basis for responsible entrepreneurship. But Leolux goes further. Our aim is a more beautiful world for the next generations. And we want to tell you how we are trying to achieve this.



The leather from Leolux comes exclusively from certified tanneries. For an animal-free lifestyle, however, you can also opt for 'artificial leather'.

Local bespoke production

Leolux is based in Venlo, the Netherlands. A second production site is in Szolnok, Hungary. Within our production process, we continuously work on reducing our environmental impact. This is expressed in numerous initiatives: cleaner production methods, more efficient machines, less use of materials, solar panels, more energy-efficient buildings and cleaner trucks. Furthermore, our production process produces very little waste. And the minimum quantities of residual materials are reused wherever possible.

Responsible materials

Your Leolux is made from sustainably produced beech wood. We are also well on our way to getting full (PEFC)

certification for other wood types. Furthermore, we only use certified foam types with a very long lifespan. And we use our waste to produce our own 'Eco-fill' cushion filling.

Leather and fabric

All partner tanneries with which we work account for their leather production methods through certifications. Our fabrics are certified according to the standards of Oeko-Tex, Greenguard, EU Ecolabel or even Cradle to Cradle.

Responsible choices

Furthermore, we offer a series of materials that reflect your sustainability wishes. We call them our 'Responsible choices' and your Leolux adviser will be happy to tell you more.

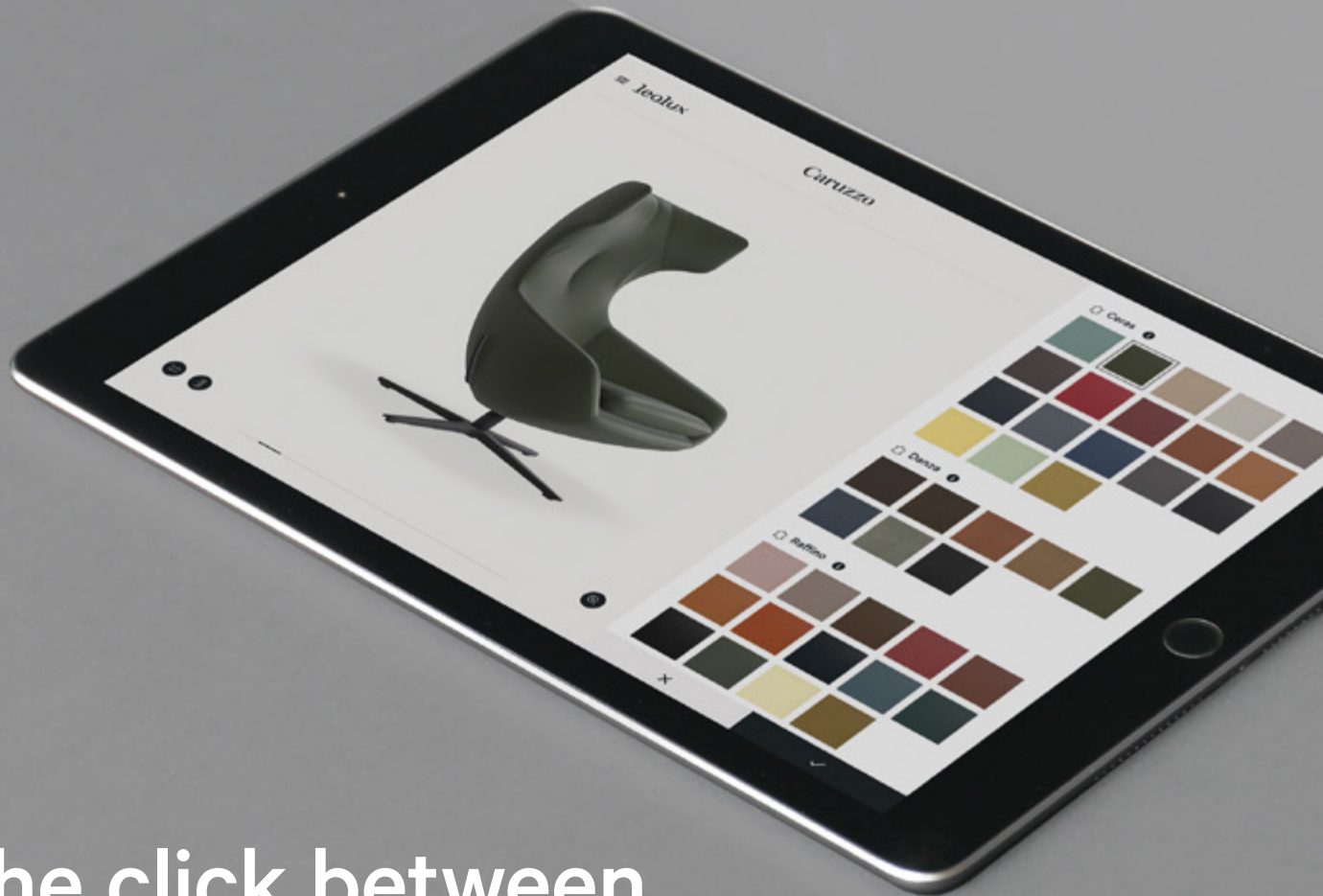

The click between you and Leolux

In the journey of discovery to a new piece of furniture, the Leolux Creator is a welcome guide. With this online product configurator, you can virtually design any Leolux product on your computer, tablet or smartphone. No version is too out there. With a simple mouse click or tap, you give your own twist to any model and any detail. Recently, the Leolux Creator also received an extensive update. Now, it is even easier to assemble the perfect true-to-life Leolux furniture.

Previously, the Leolux Creator was only available on your laptop or tablet. But now you can put together your ideal Leolux furniture on your smartphone too. So, have you had inspiration for your next sofa or armchair while you're out and about? Go to the Creator and make your ideas visible!

What piece of furniture will you create today?
Find out on creator.leolux.com



Leolux Visitor Center

In our production site in Venlo, you experience why a Leolux is such a quality product. Each step in the production process has its own charm. And we'd be delighted to demonstrate all of this during a tour of the Leolux Visitor Center.



A visit to the Leolux production site gives you the opportunity to experience how all those individual choices from design lovers across the world are translated into the most stunning furniture. You'll discover the production process step by step, following the same route as the furniture. Sometimes via skybridges, but also often from close quarters.





Exploring the many layers of human experience

YABU PUSHELBERG

At the Milan International Design Week, Leolux is presenting the new Sen armchair, an expressive single-seater designed by Yabu Pushelberg, a multidisciplinary design studio with offices in Toronto and New York. A short profile of this renowned studio.

George Yabu and Glenn Pushelberg met while studying interior design at Ryerson University in Toronto. After graduation they went their separate ways, but a few years later they met again when they were both looking for studio space. They decided to share one, and in 1980 Studio Yabu Pushelberg was born. In the early years, the focus of their work was interior design,

but over time and as the studio grew, many more disciplines were added.

Multidisciplinary practice

Today, Yabu Pushelberg is a design house, a multidisciplinary practice that focuses on the many layers of human experience. With offices in New York and Toronto and a team of more than a hundred creatives and professionals, the studio specializes in sensibilities spanning buildings, interiors, landscapes, lighting, furniture, objects, and graphics with a focus that goes well beyond what things look like, to how they make people feel.

Sen by Yabu Pushelberg

A PLAY OF DEPTH AND MOVEMENT

The new Leolux Sen armchair is a design that immediately evokes a feeling. The designers at the Canadian design studio Yabu Pushelberg were inspired by Leolux's dynamic and progressive design history.

Sen's design has a unique dynamic that is essentially very simple, yet very powerful.

The chair consists of two inverted U-shaped silhouettes within which the same shape is repeated four times, each time one step larger. This repetition is reminiscent of ripples on water. A rhythmic movement that brings an aesthetic calm to the design.

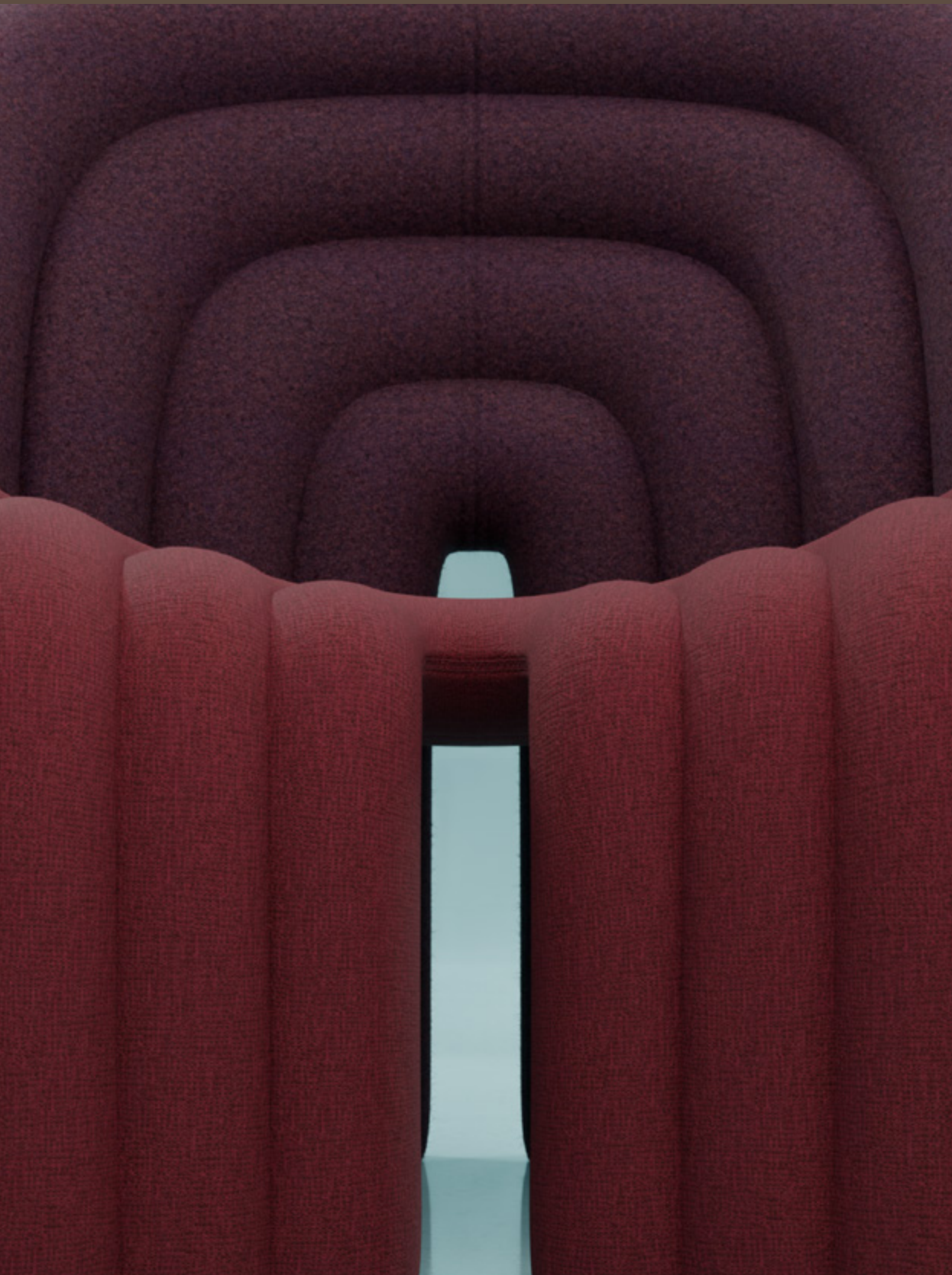



Sen by Yabu Pushelberg

THE DYNAMIC POWER OF SIMPLICITY

Sparkling

According to the designers at Yabu Pushelberg, Sen is 'a lounge chair that appears to spring to life from a fountainhead'. At the point where the seat and back meet, these two inverted U-silhouettes evoke the rhythmic movement of cascading water as it flows upward, downward and side to side. The channelled structure of the seat and back creates depth and movement with simple lines that betray the complexity of craft needed to achieve them.

Powerful flexibility

As befits a true Leolux, Sen is available in a wide range of fabrics and leathers. This gives

the chair the flexibility to adapt to any interior.

The shape is powerful enough to flow into design schemes with a neutral palette or become the show stealer with a bold choice.

Experience Sen for yourself

Curious about how Sen looks in real life and how comfortable it is? Then come to the Leolux Experience Centre in Breukelen or your nearest Leolux dealer and experience this sublime design for yourself.

A Leolux sofa is a great match for every contemporary interior, as a centre-piece or as a place to relax for the whole family. As comfort plays an important role in the Leolux philosophy, almost all Leolux designer sofas come with additional options: adjustable backs and seats, higher legs, or extra firm or extra soft. Select your own comfort, with colours and upholstery to match your requirements. A leather sofa or do you prefer a sofa upholstered in fabric? You can even choose the stitching colour from the extensive Leolux collection.

Sofas

Overview sofas



Bellice

Design: Beck Design
Inspiration – p. 24
Info – p. 198



Bora Balanza

Design: Axel Enthoven
Inspiration – p. 28
Info – p. 202



Bora Bora / Bora Bèta

Design: Axel Enthoven
Inspiration – p. 30
Info – p. 202



Devon

Design: Jan Armgardt
Inspiration – p. 32
Info – p. 203



Enna

Design: Hanne Willmann
Inspiration – p. 34
Info – p. 204



Felizia

Design: Axel Enthoven
Inspiration – p. 38
Info – p. 205



Flint

Design: Beck Design
Inspiration – p. 40
Info – p. 206



Horatio

Design: Cuno Frommherz
Inspiration – p. 44
Info – p. 207



Loya

Design: Studio Truly Truly
Inspiration – p. 46
Info – p. 208



Lunetta

Design: Studioepepe
Inspiration – p. 52
Info – p. 209

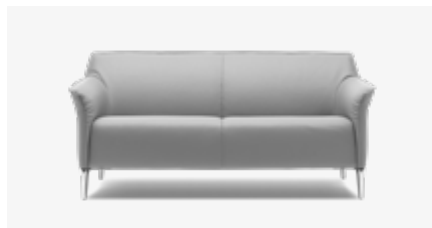

Mayon

Design: Christian Werner
Inspiration – p. 56
Info – p. 209



Modius

Design: Hanne Willmann
Inspiration – p. 58
Info – p. 210



Naila

Design: Hanne Willmann

Inspiration – p. 64

Info – p. 211



Pulla

Design: Studio Truly Truly

Inspiration – p. 68

Info – p. 212



Rego

Design: Gino Carollo

Inspiration – p. 72

Info – p. 213



Tango

Design: Jan Armgardt

Inspiration – p. 76

Info – p. 214



Bellice

Design: Beck Design, 2017

More info – p. 198





Bellice

Design: Beck Design, 2017

More info – p. 198



Bora Balanza

Design: Axel Enthoven, 2016
More info – p. 202









Bora Bora / Bora Bèta

Design: Axel Enthoven, 1983

More info – p. 202

Devon

Design: Jan Armgardt, 2018
More info – p. 203







Enna

Design: Hanne Willmann, 2022
More info – p. 204





Enna

Design: Hanne Willmann, 2022

More info – p. 204







Felizia

Design: Axel Enthoven, 2012

More info – p. 205



Flint

Design: Beck Design, 2019
More info – p. 206



Flint

Design: Beck Design, 2019
More info – p. 206







Horatio

Design: Cuno Frommherz, 2012
More info – p. 207





Loya

Design: Studio Truly Truly, 2024
More info – p. 208





Loya

Design: Studio Truly Truly, 2024

More info – p. 208



Loya

Design: Studio Truly Truly, 2024
More info – p. 208



Loya

Design: Studio Truly Truly, 2024
More info – p. 208





Lunetta

Design: Studiopepe, 2023
More info – p. 209





Lunetta

Design: Studioepepe, 2023

More info – p. 209



Mayon

Design: Christian Werner, 2012
More info – p. 209







Modius

Design: Hanne Willmann, 2025
More info – p. 210





Modius

Design: Hanne Willmann, 2025
More info – p. 210





Modius

Design: Hanne Willmann, 2025
More info – p. 210







Naila

Design: Hanne Willmann, 2023

More info – p. 211



Naila

Design: Hanne Willmann, 2023
More info – p. 211





Pulla

Design: Studio Truly Truly, 2021
More info – p. 212





Pulla

Design: Studio Truly Truly, 2021
More info – p. 212







Rego

Design: Gino Carollo, 2020
More info – p. 213





Rego

Design: Gino Carollo, 2020
More info – p. 213





Tango

Design: Jan Armgardt, 1984
More info – p. 214



An iconic element for your living room or a functional piece of furniture that completes your seating area? Leolux armchairs come in all shapes and sizes. From expressive to subtle. And almost all are fitted with functions to make sitting even more comfortable. Even if you are somewhat taller or shorter than average.

Armchairs

Overview armchairs



Anton
Design: Studio Truly Truly
Inspiration – p. 82
Info – p. 214



Caruzzo
Design: Frans Schrofer
Inspiration – p. 84
Info – p. 214



Cream
Design: Studio Truly Truly
Inspiration – p. 88
Info – p. 215



Kikko
Design: Hugo de Ruiter
Inspiration – p. 942
Info – p. 215



Kudo
Design: kaschkasch
Inspiration – p. 94
Info – p. 215



Lloyd
Design: Gino Carollo
Inspiration – p. 98
Info – p. 216



Lodey
Design: Gino Carollo
Inspiration – p. 96
Info – p. 216



Mayuro
Design: Christian Werner
Inspiration – p. 99
Info – p. 216



Pallone
Design: Boonzaaijer / Mazairac /
De Scheemaker
Inspiration – p. 100
Info – p. 217



Papageno
Design: Jan Armgardt
Inspiration – p. 102
Info – p. 217



Parabolica
Design: Stefan Heiliger
Inspiration – p. 106
Info – p. 217



Scylla
Design: Gerard Vollenbrock
Inspiration – p. 108
Info – p. 218



Sen

Design: Yabu Pushelberg

Inspiration – p. 110

Info – p. 218



THEO AND (A) THE ECHO

GUROLF STENER ALS ARCHITECT
Historia Challenge
The Hard Life
The History of Making



CASTELLANI
CASTELLANI
FOOD + DESIGN
Das Bauhaus
Innen Stadt Außen



Anton

Design: Studio Truly Truly, 2021
More info – p. 214



Caruzzo

Design: Frans Schrofer, 2015

More info – p. 214





Caruzzo

Design: Frans Schrofer, 2015
More info – p. 214







Cream

Design: Studio Truly Truly, 2020

More info – p. 215



Cream

Design: Studio Truly Truly, 2020
More info – p. 215







Kikko

Design: Hugo de Ruiter, 2000

More info – p. 215



Kudo

Design: kaschkasch, 2022

More info – p. 215







Lodey

Design: Gino Carollo, 2025

More info – p. 216



Lloyd

Design: Gino Carollo, 2018
More info - p. 216



Mayuro

Design: Christian Werner, 2013

More info – p. 216



Pallone

Design: Boonzaaijer / Mazairac / De Scheemaker, 1989

More info – p. 217





Papageno

Design: Jan Armgardt, 1993

More info – p. 217





Viewpoint Collection

leolux

LEOLUX VIEWPOINT COLLECTION

If you want to control the future, you must have the courage to look ahead. Take initiatives that explore new ground and observe the world from a different angle. This is why Leolux is introducing the Viewpoint Collection. To put products, processes and ideas in a different light and discover new paths.

The Leolux Viewpoint Collection includes products with a story. Think of experiments, one-off art projects or material studies. Sometimes we look for a new interpretation of an existing model. We use alternative materials and look for shapes which give the design a new dimension. But we also develop pieces specially for this collection. They all have one element in common: they offer a new look at the world we live in.

For this collection, we look for new collaborations. For example the glassworks of the Dutch Glass Museum. Or with Flock Techniek, a company that specialises in the coating technique 'flocking'. We also join up with artists to translate their vision on interior design and lifestyle into a unique product. In the coming years, we will continue to develop this collection, to discover and explore. And we invite everyone to join us on this journey.

BRAM

Artist and designer Bram Vanderbeke lives and works in the Belgian city of Ghent. He creates architectural objects with a distinctive aesthetic and sense of materiality, self-contained works of art that are also functional. This balance is achieved by examining the ways in which the pieces interact with their users and environment.

Materials are particularly important in Vanderbeke's work, and he has explored the properties and potential of recycled cast aluminium specifically for the Leolux Viewpoint Collection. The result is the BRAM Alu Stool, whose raw, unpolished metal finish deliberately draws attention to itself without being gimmicky.

The stool can also be used as a small table. Its three sturdy legs connected in a triangle give it a slightly tapered form, so you can stack it in one of two ways: either piled vertically, or twisted slightly so that the legs fit together.

Vanderbeke says stacking is an essential aspect of his work's architecture. Most buildings consist of elements placed atop one another, giving them a rhythm that repeatedly connects them with their surroundings.



BRAM

Design: Bram Vanderbeke, 2023
Crafted from cast aluminium



Crafted from cast aluminium
Photography: Studio Truly Truly







BRAM

Design: Bram Vanderbeke 2023

Photography: Yuta Sawamura, Chiara Catalini

KLAAR

The glass occasional table, Klaar, is a collaboration between Leolux, Studio Truly Truly and the Dutch Glass Museum in Leerdam. Klaar adds a new form of craftsmanship to our collection, which is very close to our hearts. Because there are many similarities between glassblowing and producing furniture in the way that Leolux does. Expression plays a significant role in the product and elements such as technology, teamwork and experience are essential for both processes.

Nevertheless, glassblowing is a process with a unique character. It is more explosive, a performance in which function, timing and precision come together. This is all because of the nature of the material. Glass is dissolute, it never lets itself be totally controlled. Under the influence of temperature, heat and movement, it chooses its own way. And that's exactly where the charm lies. Even when you always use the same quantities and colours, the pattern and colour gradient of each table are unique.

Studio Truly Truly designed three colour schemes for Klaar. Mottle is really intended as an eye-catcher with multiple distinct colours. This combination truly feels like a piece of art. The Lapis version combines different tints of blue. Some are transparent, while others are not. The result is slightly less complex in terms of colours, but the transparency effect is stunning. Finally, there's Nougat, with its natural tints. White, almond, creamy; for a soft and modest look. But whichever colour you go for, the transparent glass is the 'carrier'. There's a layer of transparent glass between each layer of colour, so the colours seem to float. You see that very clearly when you look at the tables from an angle.



Klaar

Design: Studio Truly Truly, 2020

Mouth-blown at the Dutch Glass Museum Leerdam

32 x 38 x 32 cm

Photography: Pim Top

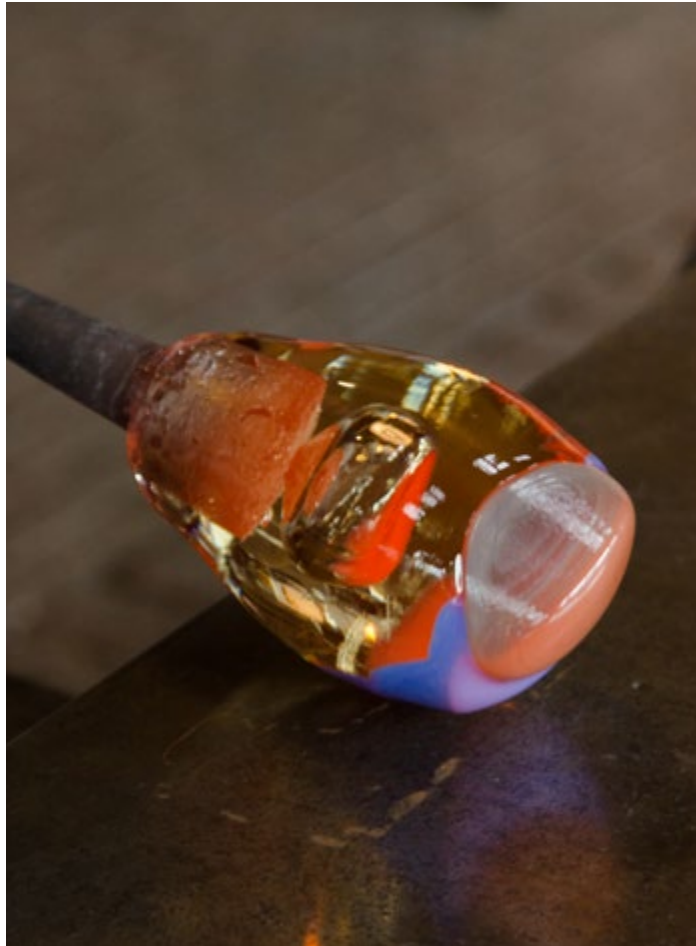

Mouth-blown in the glassworks of the Dutch Glass Museum Leerdam
Photography: Chiara Catalini







Klaar 'Lapis'
Photography: Chiara Catalini

CREAM VELVET TOUCH

Every good design has a contrast, a contradiction that evokes tension. In the original design of Cream, that's the combination of the hard wooden shell and the soft upholstery. Cream Velvet Touch is a discovery of the way in which familiar materials can evoke a new sensation. Because, by applying a special 'flock coating' to the wood, the shell gets a velvet touch. A completely different experience. And the contrast? That shifts to an intense colour pallet.

This exclusive edition combines a special design with a unique finishing technique. On the shell, leg and control lever, a flock coating is applied. A technique with numerous applications. From motor sport to the most exclusive yachts and from printer components to perfume bottles. Often a flock coating is applied for practical considerations. It reduces friction and thus noise and heat, but it also absorbs light, minimising reflections. But the unique feel and tactility formed the basis for this special version of Cream.

Flocking starts with applying an adhesive layer to the surface to be treated. An electrostatic field is then created within which tiny fibres shoot back and forth. These fibres attach to the surface, forming a high-quality velvety coating.

For this version, Studio Truly Truly selected two colour combinations. Cream Velvet Touch Red has a particularly rich robin red shell and sophisticated Raffino Whale upholstery. Cream Velvet Touch Blue exudes an ambience of absolute individuality. The strong blue colour is reminiscent of Yves Klein Blue and gives the shell a stunning contemporary look. The thick, rich Negev leather in Seco colour gives this version body and a tangible strength.



Cream Velvet Touch 'Red'
Design: Studio Truly Truly, 2020
Base and shell in red flock coating
Photography: Pim Top



Applying the flock coating at Flock Techniek in Geldrop
Photography: Chiara Catalini







Cream Velvet Touch 'Blue'
Design: Studio Truly Truly, 2020
Base and shell in blue flock coating
Photography: Pim Top



Viewpoint Gallery

Would you like to see and experience the models in the Viewpoint Collection for yourself? Then visit the special Viewpoint Gallery at the Leolux Experience Center in Breukelen.

VIEWPOINT COLLECTION

KLAAR

STUDIO TRULY TRULY, 2020



LAPIS



MOTTLE



NOUGAT

CREAM VELVET TOUCH

STUDIO TRULY TRULY, 2021



RED



BLUE

BRAM

BRAM VANDERBEKE, 2023



ALU STOOL

VIEWPOINT COLLECTION 2025-2026







Parabolica

Design: Stefan Heiliger, 2009
More info – p. 217



Scylla

Design: Gerard Vollenbrock, 1996

More info – p. 218







Sen

Design: Yabu Pushelberg, 2025

More info – p. 218

Sitting should always be comfortable. This, of course, applies to the furniture in your living room, but also when seated at the table you deserve the comfort of a real Leolux. From a wonderful dining-room chair with armrests to a stylish chair for hours of comfortable lingering at the table; you're guaranteed to succeed with our tasteful collection of dining-room chairs.

Chairs

Overview chairs

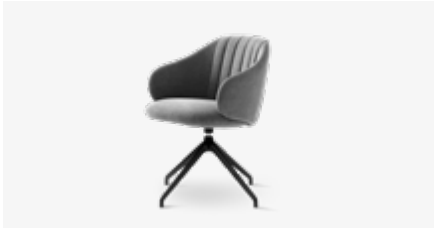

Baani

Design: Sylvain Willenz
Inspiration – p. 116
Info – p. 218



Callas

Design: Frans Schrofer
Inspiration – p. 118
Info – p. 219



Caron

Design: Frans Schrofer
Inspiration – p. 120
Info – p. 219



Gyon

Design: Christian Werner
Inspiration – p. 122
Info – p. 219



Mara

Design: Christian Werner
Inspiration – p. 124
Info – p. 220



Mime

Design: Gino Carollo
Inspiration – p. 126
Info – p. 220



Tamarinde

Design: Frans Schrofer
Inspiration – p. 128
Info – p. 220



Vynn

Design: Christian Werner
Inspiration – p. 130
Info – p. 221





Bani

Design: Sylvain Willenz, 2022

More info – p. 218



Callas

Design: Frans Schrofer, 2015
More info – p. 219







Caron

Design: Frans Schrofer, 2018
More info – p. 219



Gyon

Design: Christian Werner, 2021

More info – p. 219







Mara

Design: Christian Werner, 2016
More info – p. 220



Mime

Design: Gino Carollo, 2019

More info – p. 220







Tamarinde

Design: Frans Schrofer, 2013
More info – p. 220



Vynn

Design: Christian Werner, 2025
More info – p. 221



With a table you envision a central meeting place. A place for a delicious meal with friends, great conversation or quality time with a book or magazine. And you're entirely right in this. But a table can of course also be a handy side-table or a stylish coffee table. Whatever type of table you're looking for, you're in the right place with Leolux. You are very welcome to join us!

Tables

Overview coffee tables



BRAM
Design: Bram Vanderbeke
Inspiration – p. 136
Info – p. 221



Canopy
Design: Studio Truly Truly
Inspiration – p. 138
Info – p. 221



Dice
Design: Studio Truly Truly
Inspiration – p. 140
Info – p. 221



Elli
Design: Hanne Willmann
Inspiration – p. 142
Info – p. 222



Klaar
Design: Studio Truly Truly
Inspiration – p. 144
Info – p. 222



Liliom
Design: Beck Design
Inspiration – p. 146
Info – p. 222



Nunos
Design: Hanne Willmann
Inspiration – p. 148
Info – p. 222



Portello
Design: Patrick Belli
Inspiration – p. 150
Info – p. 223



Prismo
Design: Edward van Vliet
Inspiration – p. 152
Info – p. 223



Tampa
Design: Beck Design
Inspiration – p. 154
Info – p. 223



Toveri
Design: Studio Truly Truly
Inspiration – p. 156
Info – p. 224

Overview tables



Bondi
Design: A Design Studio
Inspiration – p. 158
Info – p. 224



Columna
Design: Hugo de Ruiter
Inspiration – p. 160
Info – p. 224



Conka
Design: Studio kaschkasch
Inspiration – p. 162
Info – p. 225



Taival
Design: Studio Truly Truly
Inspiration – p. 164
Info – p. 225



Tico
Design: Beck Design
Inspiration – p. 166
Info – p. 225



Toveri Dining
Design: Studio Truly Truly
Inspiration – p. 168
Info – p. 226



BRAM

Design: Bram Vanderbeke, 2023
More info – p. 221





Canopy

Design: Studio Truly Truly, 2025

More info – p. 221







Dice

Design: Studio Truly Truly, 2022

More info – p. 221



Eli

Design: Hanne Willmann, 2023

More info – p. 222





Klaar

Design: Studio Truly Truly, 2020

More info – p.222







Liliom

Design: Beck Design, 2010
More info – p. 222



Nunos

Design: Hanne Willmann, 2022

More info – p. 222







Portello

Design: Patrick Belli, 2013

More info – p.223



Prismo

Design: Edward van Vliet, 2017
More info – p. 223





Tampa

Design: Beck Design, 2019
More info – p. 223









Toveri

Design: Studio Truly Truly, 2021

More info – p. 224



Bondi

Design: A Design Studio, 2019

More info – p. 224





Columna

Design: Hugo de Ruiter, 2016
More info – p. 224





Conka

Design: Studio kaschkasch, 2025

More info – p. 225





Taival

Design: Studio Truly Truly, 2024

More info – p. 225







Tico

Design: Beck Design, 2021

More info – p. 225



Toveri Dining

Design: Studio Truly Truly, 2022

More info – p. 226



Each interior is a composition. A totality of elements, large and small, that together determine the ambiance. Your ambiance. For a sublime total look, Leolux offers you a wide selection of the most beautiful accessories. Create a beautiful basis with a high-quality rug and add the finishing touches with a stylish decorative cushion. Your interior only really feels complete with Leolux accessories.

Accessories

Overview accessories



Amulet

Design: Edward van Vliet

Inspiration – p. 191

Info – p. 229



Cosy Cushions

Design: Studio KZ15

Inspiration – p. 174

Info – p. 226



Cushion Lusso

Design: Studio KZ15

Inspiration – p. 175

Info – p. 226



Amund

Design: Maghalie Dooms

Inspiration – p. 176

Info – p. 227



Bolmin

Design: Studio Truly Truly

Inspiration – p. 178

Info – p. 229

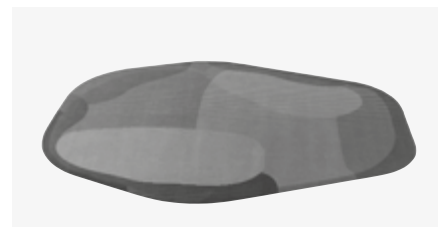

Foliage

Design: Studio Truly Truly

Inspiration – p. 180

Info – p. 227

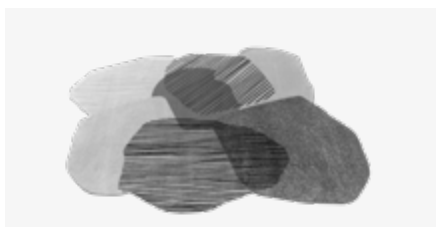

Patio

Design: Studiopepe

Inspiration – p. 182

Info – p. 228



Patna

Design: Leolux

Inspiration – p. 184

Info – p. 228

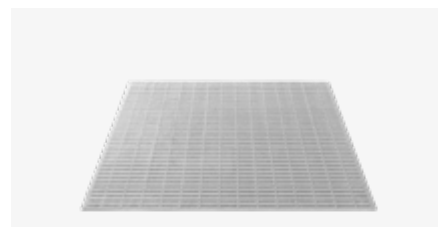

Valleys

Design: Studio Truly Truly

Inspiration – p. 186

Info – p. 229



Cosy Cushions

Design: Studio KZ15, 2013
More info – p. 226



Cushion Lusso

Design: Studio KZ15, 2018

More info – p. 226





Amund

Design: Maghalie Dooms, 2020
More info – p. 227



Bolmin

Design: Studio Truly Truly, 2025

More info – p. 229







Foliage

Design: Studio Truly Truly, 2025
More info – p. 227



Patio

Design: Studiopepe, 2023

More info – p. 228

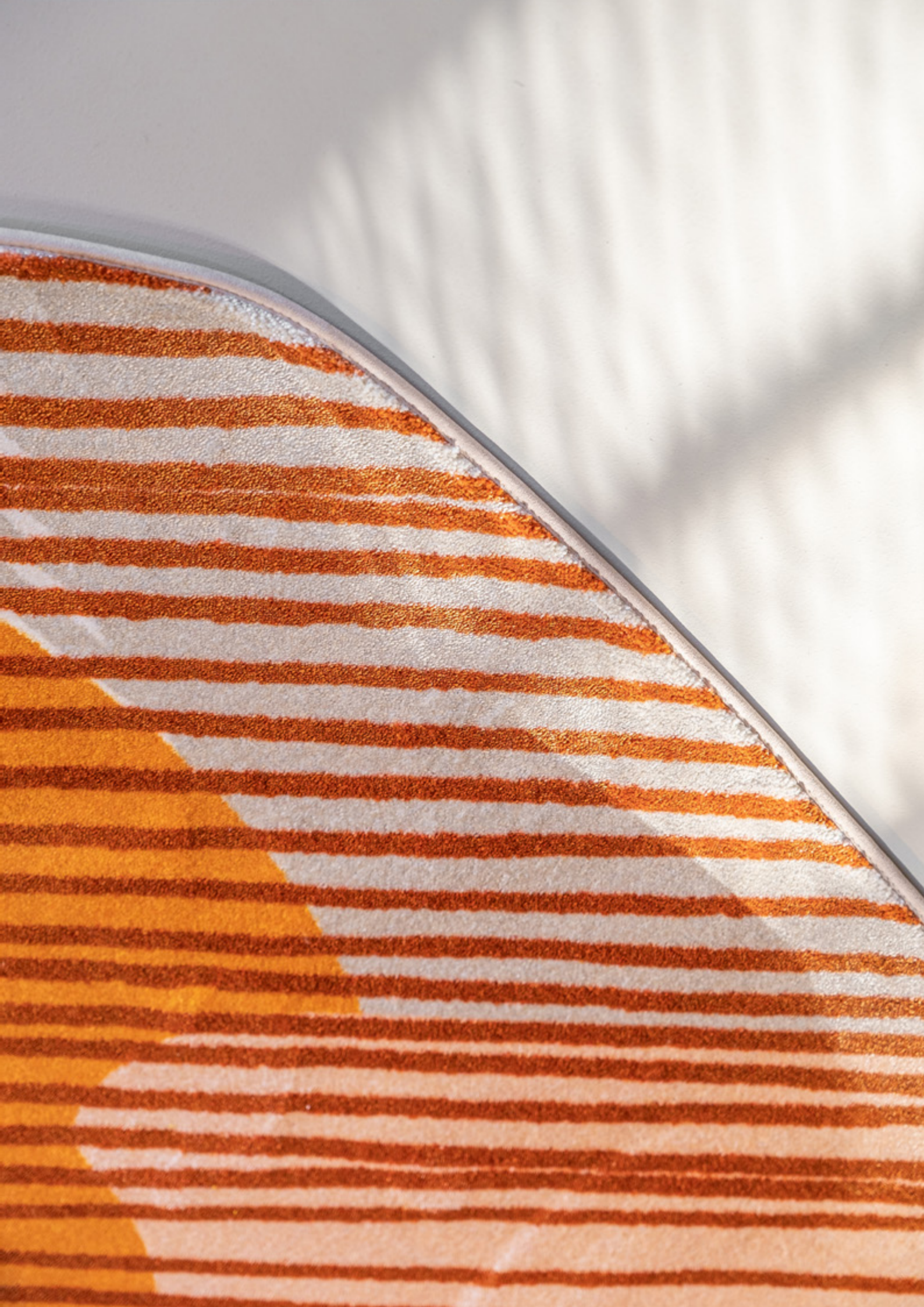



Patna

Design: Leolux, 2018
More info – p. 228



Valleys

Design: Studio Truly Truly, 2023

More info – p. 229



Overview footstools



Anton
Design: Studio Truly Truly
Armchair – p. 82
Info – p. 214



Amulet
Design: Edward van Vliet
Info – p. 229



Bellice
Design: Beck Design
Sofa – p. 24
Info – p. 198

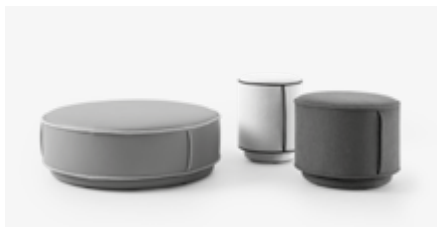

Bolmin
Design: Studio Truly Truly
Accessories – p. 178
Info – p. 229



Bora Balanza
Design: Axel Enthoven
Sofa – p. 28
Info – p. 202



Bora-Bora / Bora-Bèta
Design: Axel Enthoven
Sofa – p. 30
Info – p. 202



Caruzzo (Forte)
Design: Frans Schrofer
Armchair – p. 84
Info – p. 214



Caruzzo (Fine)
Design: Frans Schrofer
Armchair – p. 84
Info – p. 214



Cream
Design: Studio Truly Truly
Armchair – p. 88
Info – p. 215



Devon
Design: Jan Armgardt
Sofa – p. 32
Info – p. 203



Enna
Design: Hanne Willmann
Sofa – p. 34
Info – p. 204



Felizia
Design: Axel Enthoven
Sofa – p. 38
Info – p. 205



Flint

Design: Beck Design
Sofa – p. 40
Info – p. 206



Horatio

Design: Cuno Frommherz
Sofa – p. 44
Info – p. 207



Kudo

Design: Studio kaschkasch
Armchair – p. 94
Info – p. 215



Lloyd

Design: Gino Carollo
Armchair – p. 98
Info – p. 216



Lodey

Design: Gino Carollo
Armchair – p. 96
Info – p. 216



Loya

Design: Studio Truly Truly
Sofa – p. 46
Info – p. 208



Loya

Design: Studio Truly Truly
Sofa – p. 46
Info – p. 208



Mayon

Design: Christian Werner
Sofa – p. 56
Info – p. 209



Mayuro

Design: Christian Werner
Armchair – p. 99
Info – p. 216



Modius

Design: Hanne Willmann
Sofa – p. 58
Info – p. 210



Naila

Design: Hanne Willmann
Sofa – p. 64
Info – p. 211



Pallone

Design: Boonzaaijer / Mazairac /
De Scheemaker
Armchair – p. 100
Info – p. 217



Pulla
Design: Studio Truly Truly
Sofa – p. 68
Info – p. 211



Pulla
Design: Studio Truly Truly
Sofa – p. 68
Info – p. 211



Rego
Design: Gino Carollo
Sofa – p. 72
Info – p. 212



Rego
Design: Gino Carollo
Sofa – p. 72
Info – p. 212



Scylla
Design: Gerard Vollenbrock
Armchair – p. 108
Info – p. 217



Amulet

Design: Edward van Vliet, 2017

More info – p. 230

A Leolux is all about feeling. It's about the look that conquers your heart and the comfort that always supports you. But you also know that every product that leaves our factory is a unique one. That is why we would like to give you an overview of the details and options to make your furniture personal.

Product information

Index

- 196 Your Leolux in the best condition
- 196 Service and warranty

Sofas

- 198 Bellice
- 202 Bora Balanza
- 202 Bora Bora / Bora Bèta
- 203 Devon
- 204 Enna
- 205 Felizia
- 206 Flint
- 207 Horatio
- 208 Loya
- 209 Lunetta
- 209 Mayon
- 210 Modius
- 211 Naila
- 212 Pulla
- 213 Rego
- 214 Tango

Armchairs

- 214 Anton
- 214 Caruzzo
- 215 Cream
- 215 Kikko
- 215 Kudo
- 216 Lloyd
- 216 Lodey
- 216 Mayuro
- 217 Pallone
- 217 Papageno
- 217 Parabolica
- 218 Scylla
- 218 Sen

Chairs

- 218 Baani
- 219 Callas
- 219 Caron
- 219 Gyon
- 220 Mara
- 220 Mime
- 220 Tamarinde
- 221 Vynn

Coffee tables

- 221 BRAM
- 221 Canopy
- 221 Dice
- 222 Elli
- 222 Klaar
- 222 Liliom
- 222 Nunos
- 223 Portello
- 223 Prismo
- 223 Tampa
- 224 Toveri

Tables

- 224 Bondi
- 224 Columna
- 225 Conka
- 225 Taival
- 225 Tico
- 226 Toveri Dining

Accessories

- 226 Cosy Cushions
- 226 Cushion Lusso
- 227 Amund
- 227 Frame
- 228 Patio
- 228 Patna
- 229 Valleys
- 229 Amulet
- 229 Bolmin

- 230 Materials
- 244 Leolux Centers

Icons



Lower

This model is available with lower feet or armrests.



Higher

This model is available with higher feet or armrests.



Shorter seat depth

Available with a shorter or adjustable seat, or fitted with a thicker back cushion. Ideal for smaller users.



Longer seat depth

Available with a longer seat, or fitted with an adjustable seat. Ideal for bigger users.



Tilt

Armchair with a mechanism that enables you to adjust the tilt of the entire seat, forwards or backwards.



Adjustable backrest

The backrest can be adjusted as required– you can choose for a “lazier” or more upright position.



Swivel

Armchair with a mechanism that enables you to swivel the seat.



Adjustable arm and/or back parts

This model can be adapted to the mood of the moment by adjusting the arms or parts of the backrest.



Castors

Available with castors which enable you to move this seating concept around with even more ease.



Leather

This product is available in leather.



Fabric

This product is available in fabrics.



Lacquer

This product is available in various Leolux lacquer, stain or epoxy colours.





Your Leolux in the best condition

Our craftsmen incorporate the most beautiful and best materials in your own item of furniture. That's why our products have a long lifespan.

But with a little maintenance, you can keep your Leolux in even better condition. Of course, we'd like to tell you how best to do this. That's why our website contains maintenance instructions for all materials that we use.

Check www.leolux.com to keep your sofa, armchair, table or rug in the very best condition!



Service and warranty

Leolux strives to provide you with a perfect product. Even so, something can always go wrong. After all, the making of a piece of Leolux furniture remains handmade. If something is not in order, we will correct it for you. And if something goes wrong at a later date, then the Leolux warranty provides reassurance.

If you experience a problem, your dealer is the first person to contact, however, you can also contact Leolux directly. You can contact our service department via the Leolux website. There you will find our complete warranty scheme, useful maintenance tips and the serviceshop, where you can quickly and easily purchase small parts and maintenance products.

More information about service and maintenance:
www.leolux.com/support



Bellice

Inspiration – p. 24

Design: Beck Design, 2017

A real beauty, versatile and inviting. Bellice brings together taste, ambiance and living styles thanks to the extensive range of options and timeless refinement of its finishing. You can see this in the hand-knotted decorative stitching and the loosely upholstered cushions, and you can feel it in the comfort.

The Bellice range is unique in terms of its possibilities. You can define the dimensions, comfort and versions exactly as you want them, so that they fit in every interior. Your own individual style determines the shape that Bellice takes.

Cushion width

Your Bellice starts with the seat width. This is the first decision you need to make before you choose the legs, arms, upholstery materials or colours. Bellice is available as an armchair, or as a sofa with two 70, 80, 90, 100, or 110 centimetre cushions. Virtually all these widths are also available for the modular elements. There are also the XL sofas sized 3 x 80 or 3 x 90 centimetres, as well as tables measuring 55 and 80 centimetres wide, which can be placed between or at the end of modular elements.

Comfort

Some people prefer a firm comfort; others love a soft comfort. Nothing is more personal than seating comfort. So when you buy a Bellice, you can choose from different levels of comfort for both the seats and the back cushions.



Medium

The medium comfort level has a foam core, supplemented with high-quality flock filling.



Semi-firm

With the option Semi-firm, you choose a filling that consists entirely of HR-foam.



Firm

This option has a filling of HR-foam with a higher density, making it the firmest of all comfort styles.



All upholstery will develop creases over time.

However, these creases are kept to a minimum in shape-stable cushions.

Arms

It may seem a mere detail, but when you see the different versions, you suddenly realise how much an arm changes the appearance of your sofa. So with the Bellice, you can choose from no fewer than five arm types: slim-low, slim-high, wide-low, wide-high and slim-adjustable.



Slim-low



Slim-high



Wide-low



Wide-high



Slim-adjustable

Base

Multiple base options are available for the Bellice. You have plenty of choice, from sleek to decorative; every leg or sledge base will give your sofa a different look. The Fino, Grazio and Sobrio legs, and the Anillo sledge base can be optionally lacquered or powder coated (epoxy).



Fino



Grazio



Sobrio



Anillo

Bellice

Inspiration – p. 24

Design: Beck Design, 2017

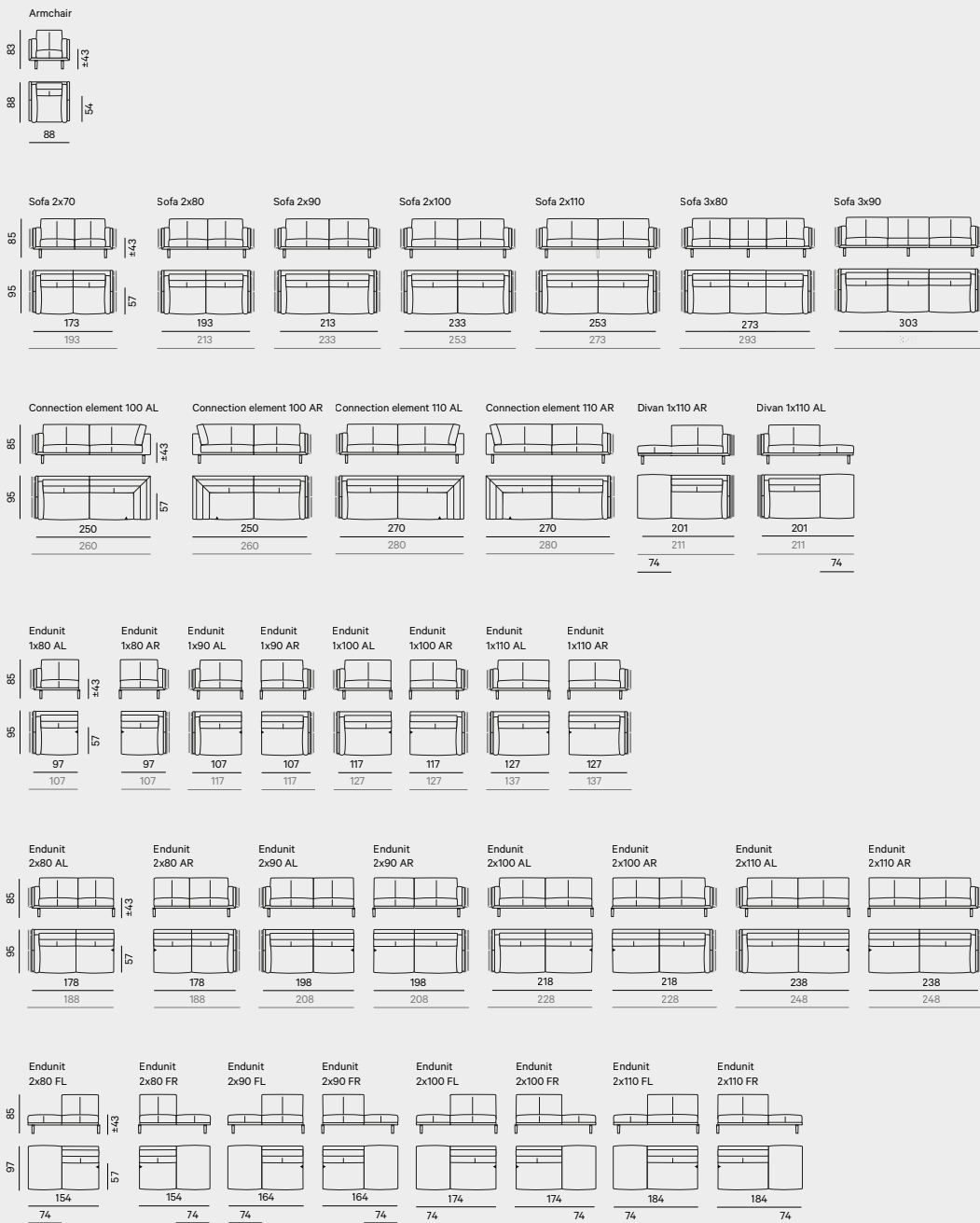

Bellice

Inspiration – p. 24

Design: Beck Design, 2017

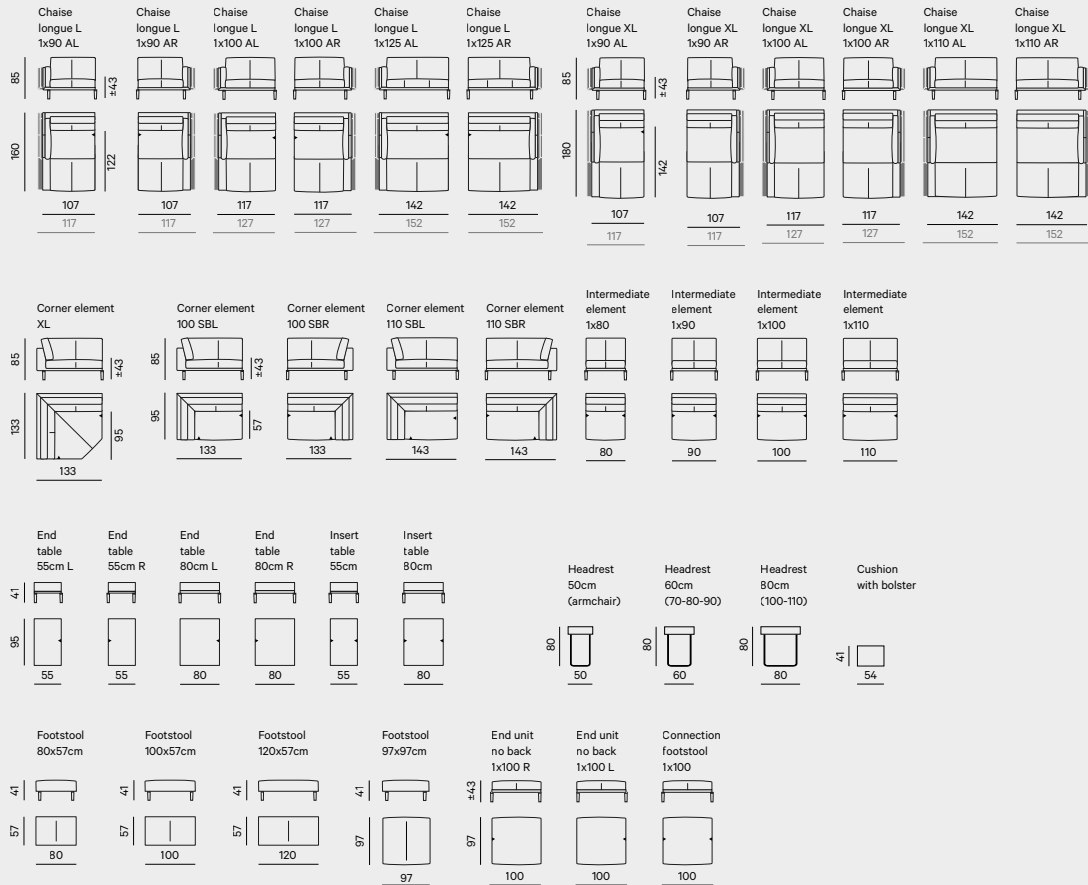

Examples

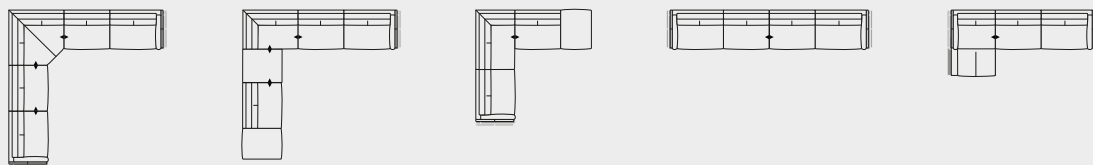

Bora Balanza

Inspiration – p. 28

Design: Axel Enthoven, 2016

The connoisseur will immediately recognise that the inspiration for Bora Balanza is derived from the successful 1980s-era Bora series. However, designer Axel Enthoven used a completely new approach to the basic principle of comfort and hidden beauty, entirely in keeping with these times. The result is both comfortable and beautiful. A reborn Bora, in total balance.

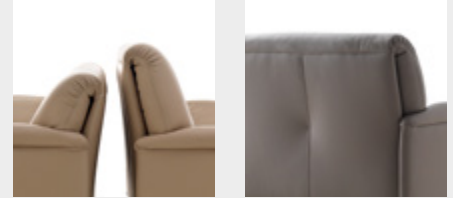
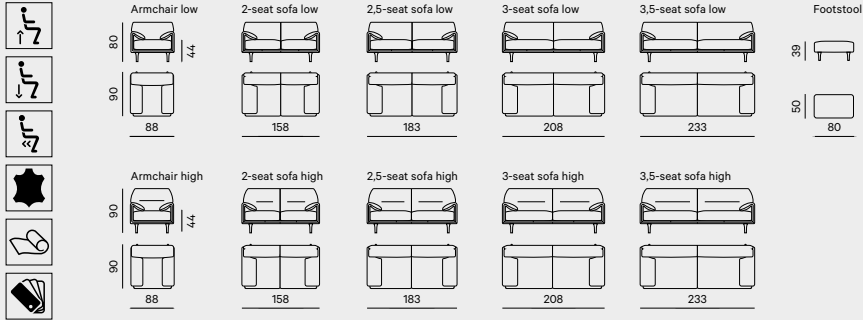

Bora Bora / Bora Bèta

Inspiration – p. 30

Design: Axel Enthoven, 1983

The Boras were truly revolutionary at the time. The design was so light and subtle, it was simply unparalleled. Axel Enthoven created an interplay between forms, on which time has no influence. Bora Bora and the higher Bèta version are unchanged classics, with the soft arms and backs that mould themselves to your body offering extremely high comfort levels.

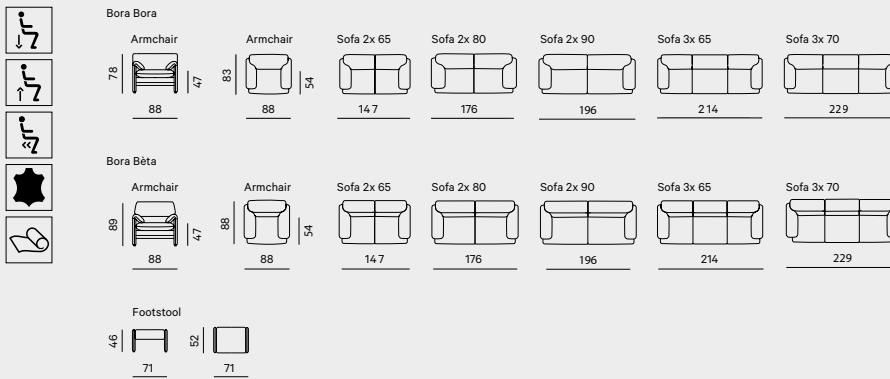

Devon

Inspiration – p. 32

Design: Jan Armgardt, 2018

This sofa programme combines the design quality of Jan Armgardt with renowned Leolux craftsmanship. From an individual sofa or chaise longue to a generous modular set. Whatever you choose, every Devon version offers adjustability for creating the ultimate in comfort. The beautiful crafted details ensure that Devon is immediately recognisable as a true Leolux sofa, but with its own unique look.

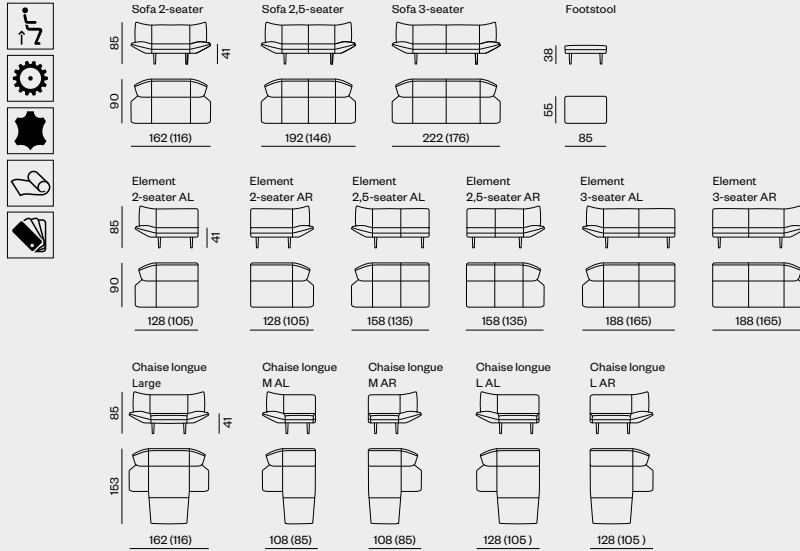
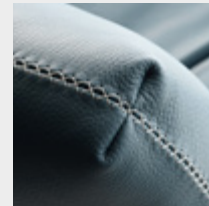
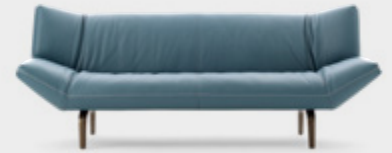

Enna

Inspiration – p. 34

Design: Hanne Willmann, 2022

With Enna you can use a wide range of sofas, divans and elements to create either generous or compact configurations. The elegant metal frame firmly holding the cushions in its grip is a typical feature and can be finished in any colour you could wish for. The 'Bent' arm cushions folded around the arms form a playful alternative to the 'Straight' arm cushions. Enna is the refreshing exponent of a new generation of designs.

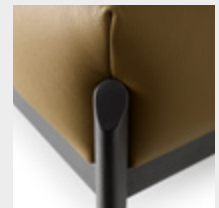
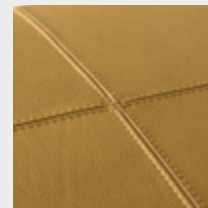
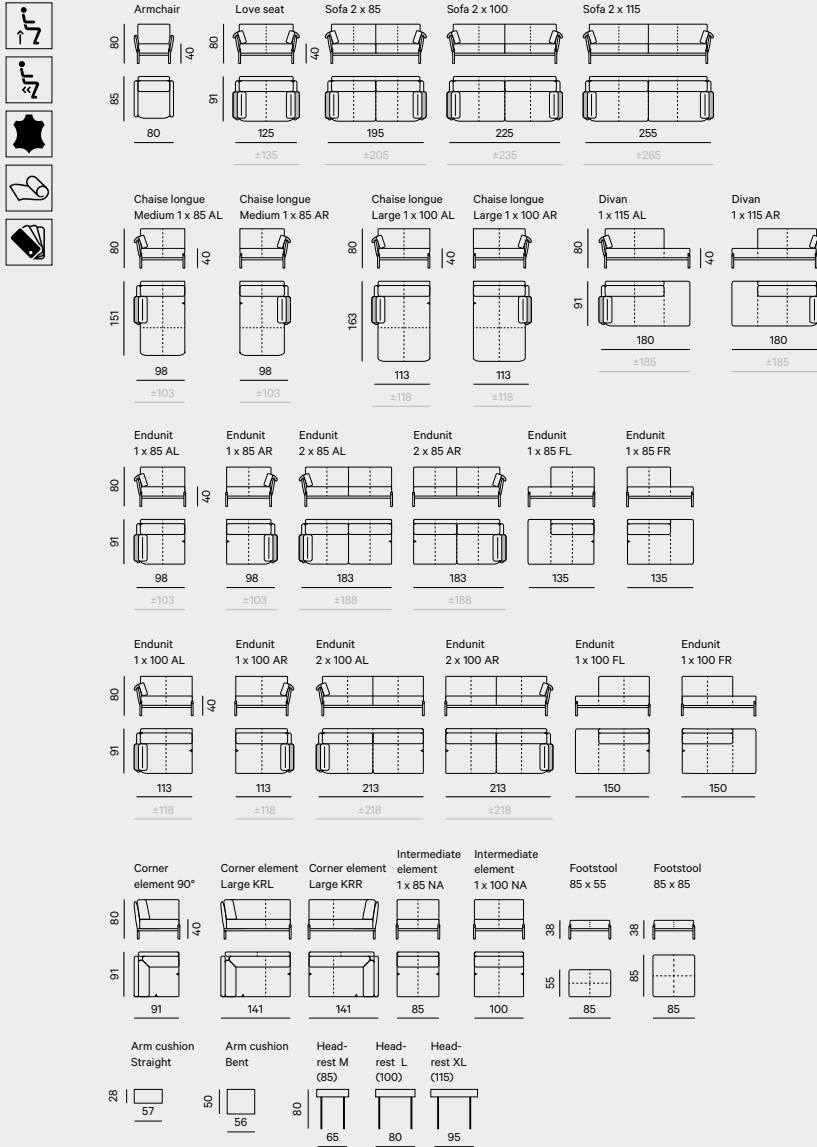

Example

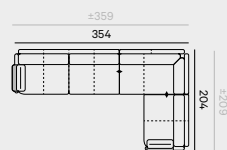
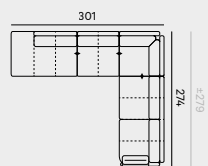
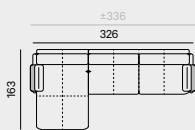

Flint

Inspiration – p. 40

Design: Beck Design, 2019

An extensive programme, with sofas, divans and modular elements to create large and small configurations. Such as a 90 degree corner or an exciting angled combination. The organic shapes of the seats and arms give Flint a friendly look, enhanced by its generous loose seating cushions. Flint is a bundle of energy, a strong design that demands its own place in your room.

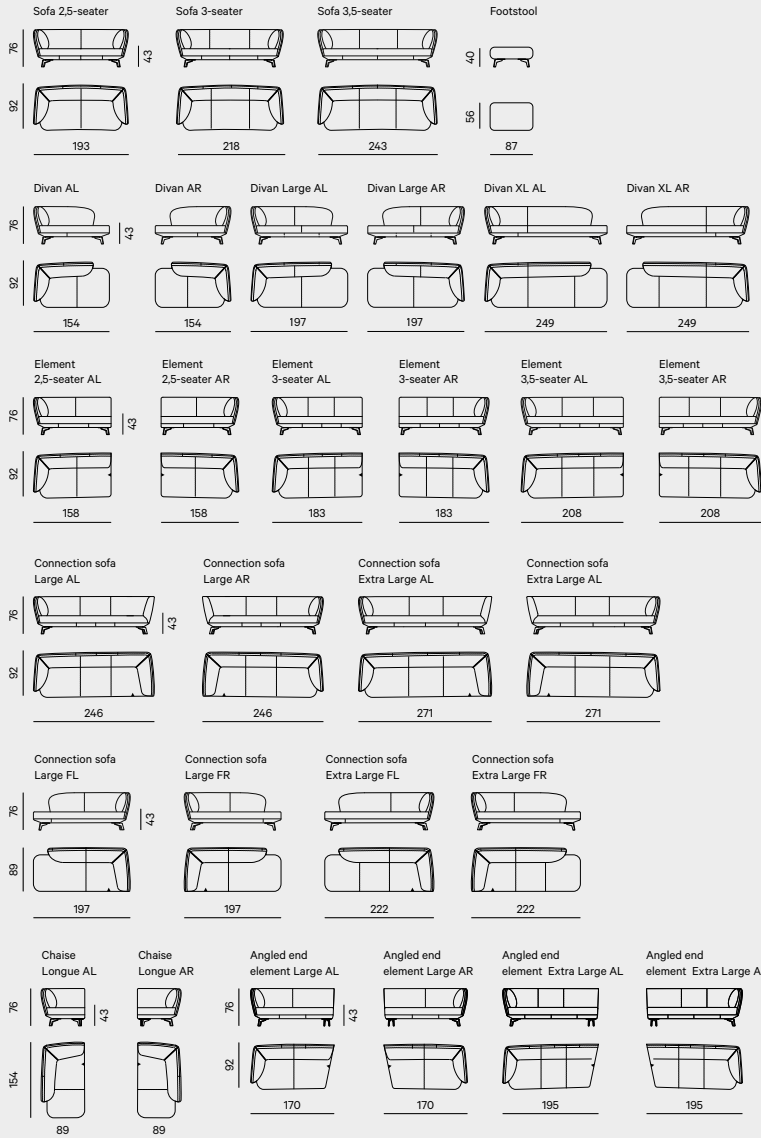

Example

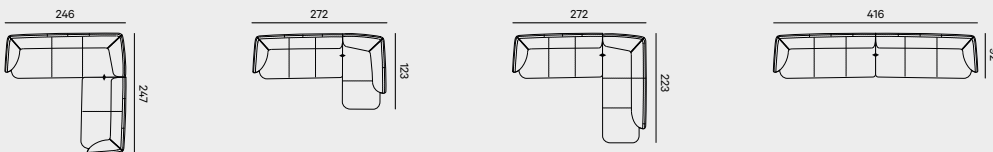

Horatio

Inspiration – p. 44

Design: Cuno Frommherz, 2012

A low back is nice, but not always as comfortable as you would like. Cuno Frommherz found the solution in swivel headrests. They retain the low look of the design and transform the nimble Horatio sofa into a chaise longue in no time at all. Cleverly conceived, beautifully crafted and nobly finished, on legs or skids. Horatio is available as a loveseat, connection sofa and 3-seater sofa.

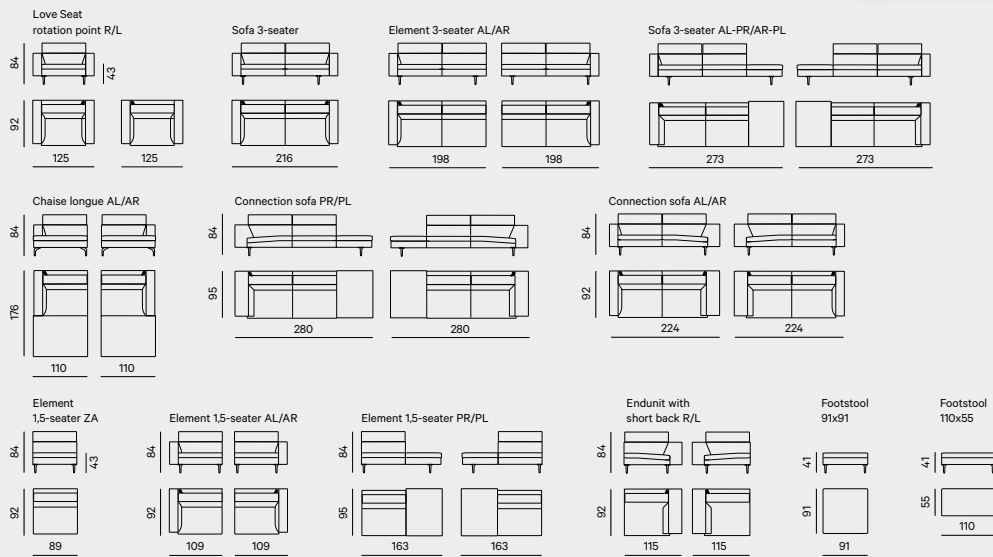

Example

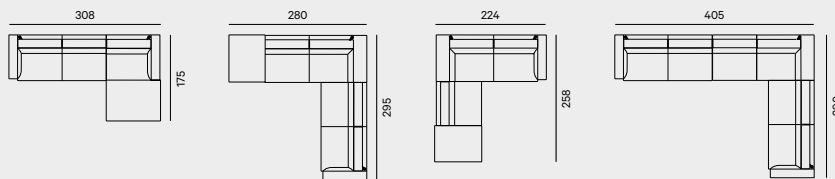

Loya

Inspiration – p. 46

Design: Studio Truly Truly, 2023

The Loya sofa is an open invitation to make yourself comfortable, elegantly crafted with exceptional attention to detail and combining generous proportions with an aura of total softness. Kate and Joel Booy of Studio Truly Truly based their design on what they call the ‘soft mass’ principle, imparting volume to a two-dimensional material. The sofa takes linear geometric forms and expands them into a composition of soft blocks, offering unparalleled comfort.

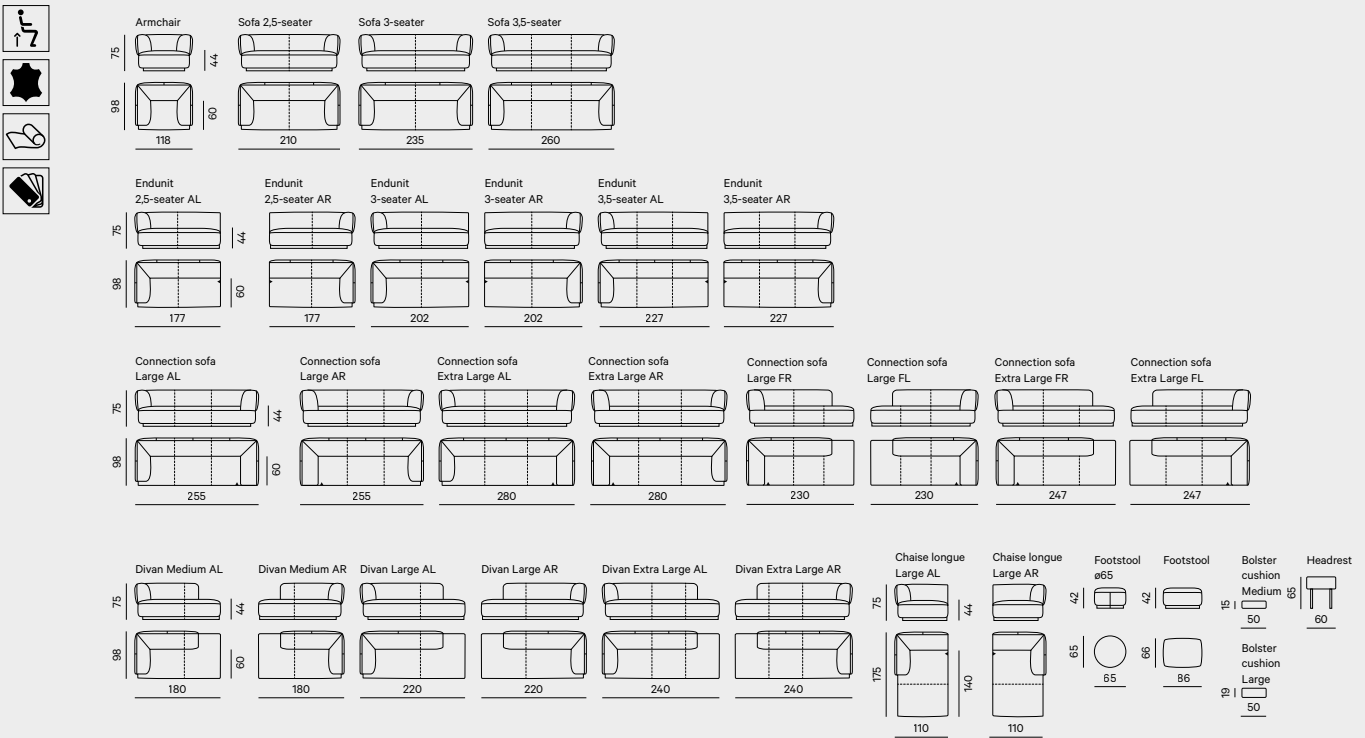

Example

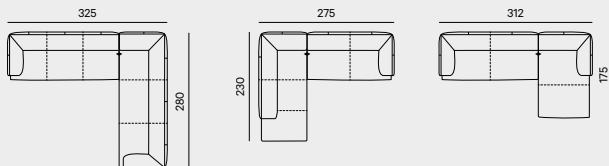

Lunetta

Inspiration – p. 52

Design: Studiopepe, 2023

Lunetta is designed for relaxation, shaping itself to your position and fitting in with your lifestyle. When you sit down, it embraces you like a blanket, with the loose-filled arm cushions adapting instantly to your body. It's extremely comfortable, in a nonchalant kind of way.

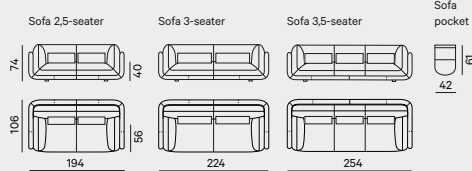

Mayon

Inspiration – p. 56

Design: Christian Werner, 2012

The organic forms that characterise Christian Werner designs are what make Mayon an elegant item of furniture with crafted details. The integrated springs ensure that the flexible arms align themselves to your body. Each aluminium leg is a jewel that seems to have been created from the seat in a flowing movement, certainly if lacquered in a matching colour. The compact Mayuro armchair is a perfect design companion to the Mayon.

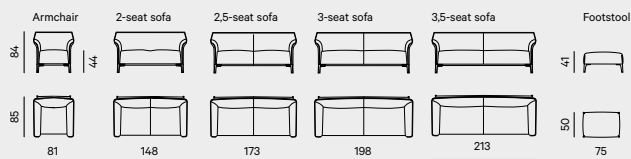

Modius

Inspiration – p. 58

Design: Hanne Willmann, 2025

Design from and for a new generation: With Modius, Hanne Willmann has designed a sleek and compact sofa range. Young and modern with fine comfort, two back heights and soft armrests that allow you to lie down comfortably on this sofa. So if you want to relax in comfort, on a sofa that does not take up all the space in your room, Modius is the perfect choice.

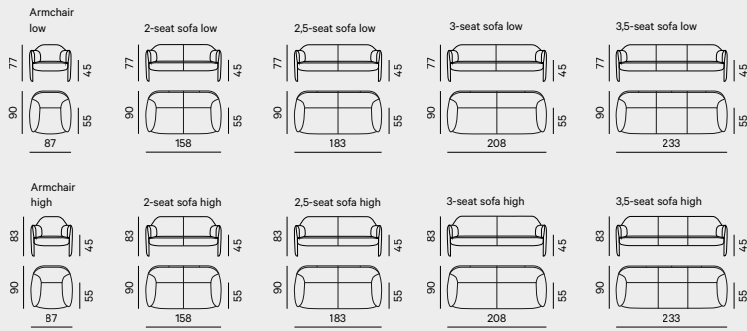

Naila

Inspiration – p. 64

Design: Hanne Willmann, 2023

Naila just invites you to sink into its embrace. The seat is a little lower and deeper for added relaxation – and if you appreciate attention to detail, this elegant design by Hanne Willmann will be right up your street.

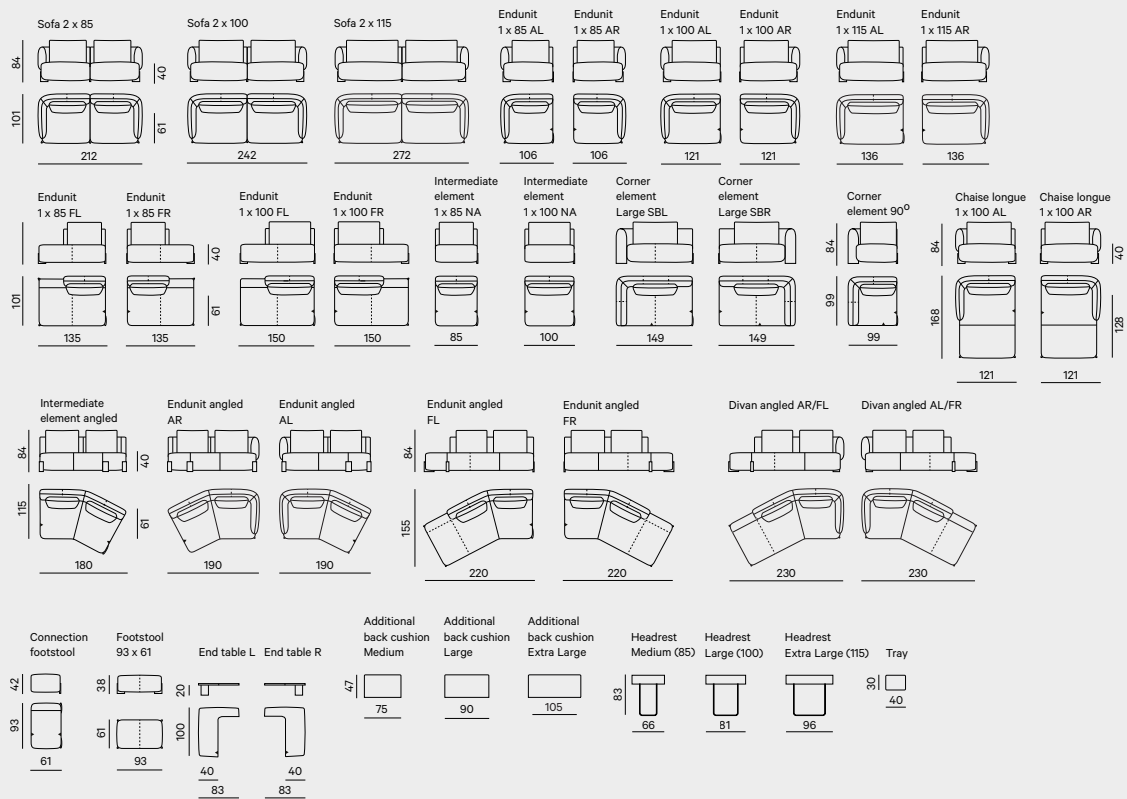
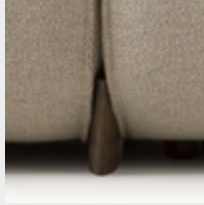

Example

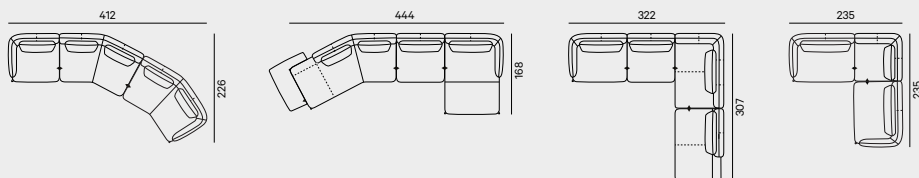

Pulla

Inspiration – p. 68

Design: Studio Truly Truly, 2021

Pulla is the result of a study into forms and materials and their relationship to the space in which they fulfil their function. The outcome of this search is a timeless sofa in which the lines and materials are interwoven. They merge to form a comfortable seating programme with a soft and low look and a larger seating depth. This looks stunning in large interiors but is just as suitable for intimate, more compact rooms.

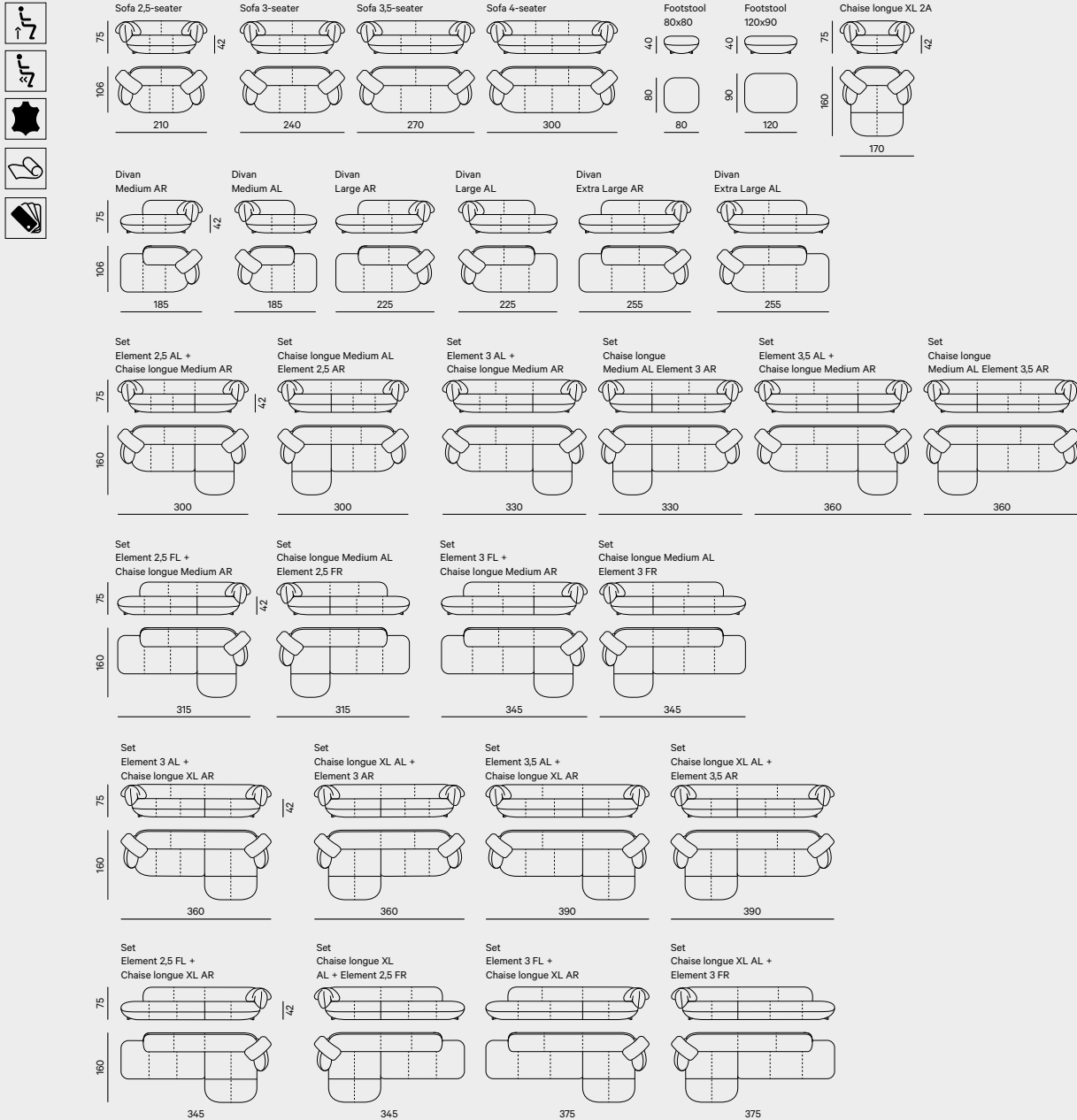

Rego

Inspiration – p. 72

Design: Gino Carollo, 2020

Rego is a design with pure Italian elegance. Original design enthusiasts will really love the curved elements. The curve is very slight, which provides an exciting visual effect, and they look absolutely stunning in combination with the round chaise longue.

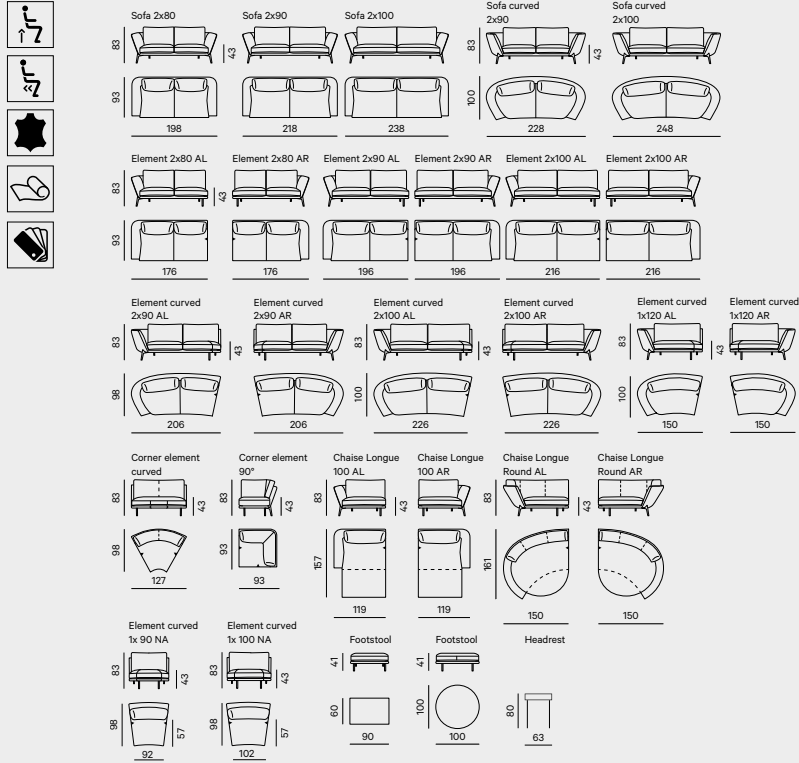

Example

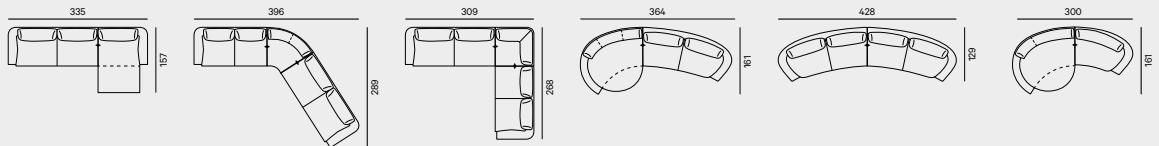

Tango

Inspiration – p. 76

Design: Jan Armgardt, 1984

A true 'classic' that has been a trendsetter for four decades. The Tango seat and back have adjustable left and right sections offering alternative application options in all positions. A cosy 2-seater can be transformed into a wonderful reclining sofa with headrest and the generous 3-seater becomes even more spacious. Enjoy the beautiful features of this flexible character sofa.

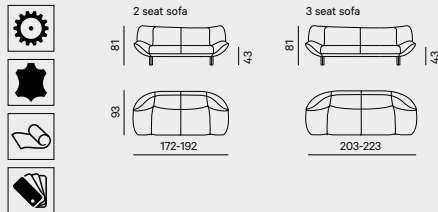

Anton

Inspiration – p. 82

Design: Studio Truly Truly, 2021

The design of the Anton armchair alludes to the past and to the hand-crafted quality products with which Leolux made its name. The seat combines rounded and straight forms and rests on a chromed frame. This creates a luxury reading chair with sturdy arms. The designers' contemporary arrangement of the sofa elements enables playful colour and fabric combinations.

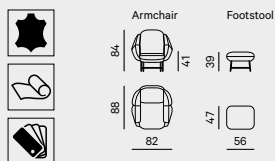

Caruzzo

Inspiration – p. 84

Design: Frans Schrofer, 2015

Caruzzo is unparalleled in many respects. The curved lines of this swivel chair create movement in this timeless design and give it momentum. With the hand-sewn 'Artisan' stitch, Leolux is presenting a powerful example of hand-crafted art, while modern technology provides the perfect seating position for every moment of the day. It's not without reason that Caruzzo was awarded the 2015 Red Dot Design Award and the 2015 Good Industrial Design award. Available with two types of bases 'Original' or 'Pure' and 2 types of footstool 'Fine' or 'Forte'.

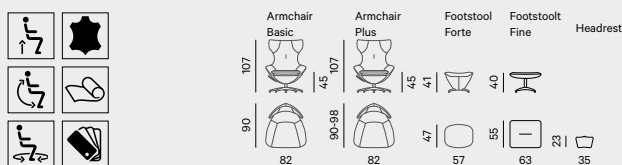

Cream

Inspiration – p. 88

Design: Studio Truly Truly, 2020

In Cream, Studio Truly Truly combines the most beautiful natural materials, producing an elegant armchair of unparalleled comfort. The focus is on the plywood shell in walnut or oak, upholstered in a soft fabric or leather. The aluminium swivel base offers even more options for customisation. This can be finished in polished aluminium or any colour for that perfect result.

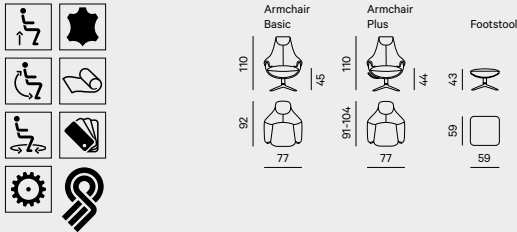

Kikko

Inspiration – p. 92

Design: Hugo de Ruiter, 2000

Is it a chaise longue? Yes, but Kikko offers many more possibilities. If you lift the back lightly, you can rotate it 90 degrees left or right, transforming your chaise longue into a truly comfortable seat. You can choose from two colours for the seat and back, offering you a canvas for tasteful combinations that are just as versatile as the comfort of this unique Hugo de Ruiter design.

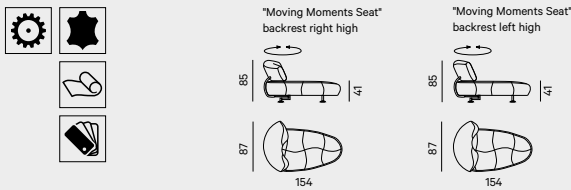

Kudo

Inspiration – p. 94

Design: kaschkasch, 2022

It all started with a single detail: the way in which the generously proportioned seat cushion contrasts against the frame. Designers Florian Kallus and Sebastian Schneider, of Studio kaschkasch, decided that this should be the basis of their first lounge chair for Leolux. The result combines simplicity with versatility and relaxed comfort.

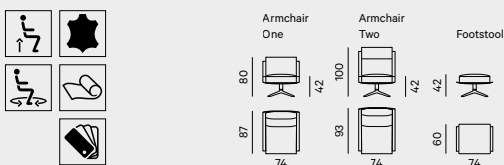

Lloyd

Inspiration – p. 98

Design: Gino Carollo, 2018

Lloyd is a design beacon in your living room. Cool, yet so inviting. With supple, almost nonchalant upholstery and crafted details, such as decorative piping to emphasise the strong shape. The inside and the outside can be chosen separately, as can the colour of the legs and the decorative stitching. The recliner lever is upholstered in leather.

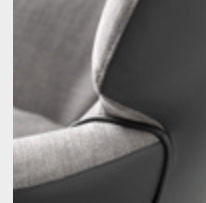
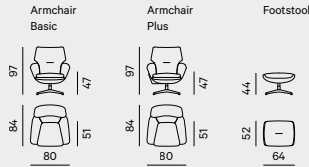

Lodey

Inspiration – p. 96

Design: Gino Carollo, 2025

Lodey is a swivel armchair offering exceptional comfort and an ultra-soft appearance. With its loose, creased upholstery, Lodey radiates softness and southern elegance. The wide backrest naturally extends from the comfortable seat shell, while the aluminum swivel base (available in any Leolux color) and leather-tipped tilt lever add beautiful, subtle details.

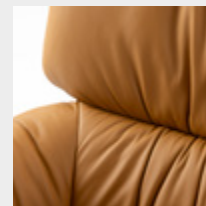
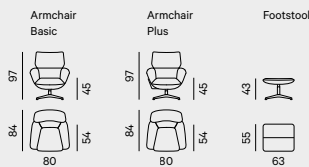

Mayuro

Inspiration – p. 99

Design: Christian Werner, 2013

Building on the successful Mayon series, Leolux has created the Mayuro armchair, with more compact dimensions and active comfort. The beautiful upholstery accents, including attractive dimples in the sides and loose upholstery are what make Mayuro truly elegant, just like the specially designed legs. All these elements create stunning enrichment for contemporary interiors.

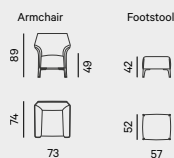

Pallone

Inspiration – p. 100

Design: Boonzaaijer / Mazairac / De Scheemaker, 1989

This was originally designed for the House of the Future. Pallone is perhaps the best-known Leolux armchair. This is undoubtedly due to its futuristic design, but without the legendary Leolux comfort the relevance would certainly have been lost. Available in multiple sizes and in numerous colour and upholstery fabric options. Pallone has personality, and is the perfect eye-catcher for distinctive interiors.

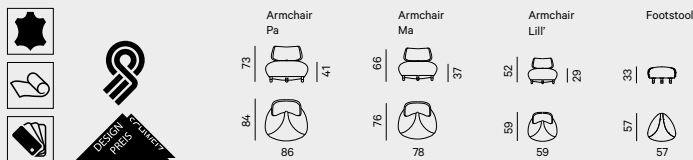

Papageno

Inspiration – p. 102

Design: Jan Armgardt, 1993

Papageno is the Leolux symbol for playfulness, amusement and humour. The striking aluminium legs, the lightly sprung back and beautiful organic form make Papageno an eye-catcher that's difficult to date. And yet this Leolux classic has been around for over thirty years. Arty and playful, design with stunning organic forms.

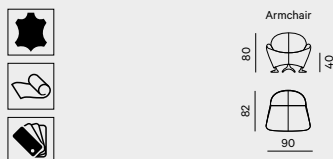

Parabolica

Inspiration – p. 106

Design: Stefan Heiliger, 2009

With its powerful design, the Parabolica swivel chair is a fantastic object in your living room. The asymmetrical form enables at least three different types of use: 'normal' sitting, relaxed reclining or active sitting with the armrest as a small workstation. A true eye-catcher, with tremendous versatility. You can select different upholstery for the inside and the outside and the band between the two.

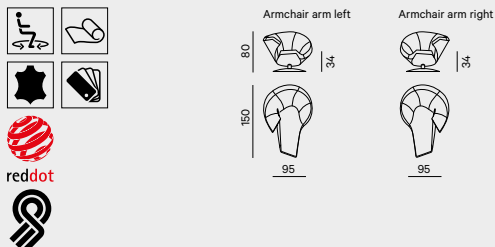

Scylla

Inspiration – p. 108

Design: Gerard Vollenbrock, 1996

Gerard Vollenbrock designed this traditional Dutch Scylla with references to 'De Stijl'. He gave the sober design a stunning tube frame that runs entirely along the back and sturdy upholstered armrests. It is the small details and perfectionist finish that ensure that this design easily passes every test, even after many years. Because it's only under these conditions that true timeless design is created.

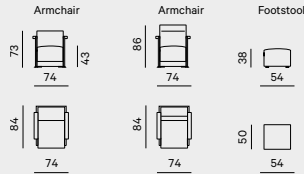

Sen

Inspiration – p. 110

Design: Yabu Pushelberg, 2025

The new Leolux armchair Sen is a design that immediately evokes a feeling. Canadian design studio Yabu Pushelberg was inspired by Leolux's dynamic and progressive design history. Sen is available in a wide range of upholstery, both in fabric and leather. This gives the armchair the flexibility to flow into design schemes with a neutral palette or become a show stealer with a bold choice. For Sen's exact sizes, check our website.



Baani

Inspiration – p. 116

Design: Sylvain Willenz, 2022

The Baani chair effortlessly combines an elegant look with attractive upholstery details. A pleated strip across the centre of the seat back provides a rich contrast, giving Baani a soft touch. The chair also offers several other options to make each set unique. The upholstery combination is extremely defining, but you can also opt for versions with or without arms and for wooden legs or an aluminium swivel base.

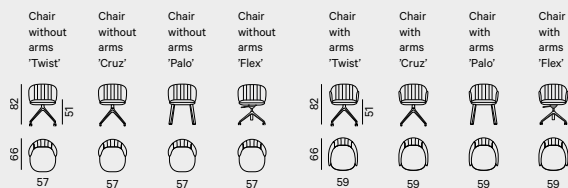

Callas

Inspiration – p. 118

Design: Frans Schrofer, 2015

Callas is an expressive eye-catcher at the table. You can select the front, back and legs for each Callas chair to create a mix that is a perfect match for your taste. As standard, Callas has a sturdy zip at the back, but for that extra grand finish, Callas offers Artisan: a skilfully sewn decorative stitch that replaces the zip at the back.

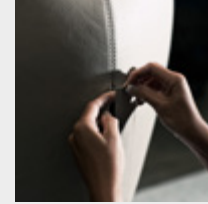
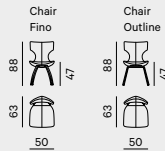

Caron

Inspiration – p. 120

Design: Frans Schrofer, 2018

The comfortable Caron bar stool is a Frans Schrofer design and is a clear continuation of the stylish elements of the Caruzzo and Callas models. The Caron finish is also entirely in line: as alternative to the sturdy zip on the back, you could decide to go for the handcrafted 'Artisan' decorative seam. It can be used as bar stool or counter height stool and you can choose from every fabric and leather from the collection for the inside and outside upholstery. It can be used as bar stool or counter height stool and has two options for the back rest height. You can choose from every fabric and leather from the collection for the inside and outside upholstery.

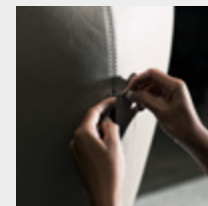
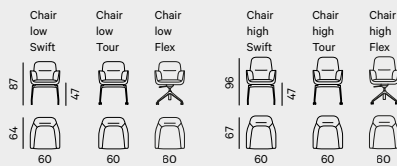

Gyon

Inspiration – p. 122

Design: Christian Werner, 2021

Designer Christian Werner created a strikingly elegant chair that does not hide its perfect seating comfort. What's more, everyone can add their own twist to the design by having the inside and outside of the chair upholstered in different fabrics. This freedom of choice also applies to the frame. Select a frame with legs, castors or height adjustment.

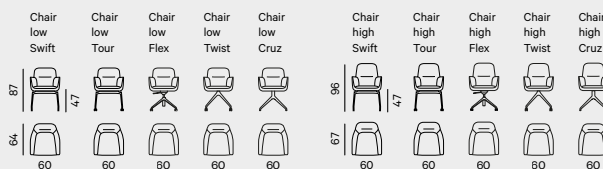

Mara

Inspiration – p. 124

Design: Christian Werner, 2016

Unmistakably a Christian Werner design: the curves of the shell seat, the light nonchalance of the upholstery, the refined finish. Mara is a fitting choice in many contemporary interiors due to the different frames: solid oak legs (Palo) are a great match for the oak tables in the Leolux collection; sleek-looking sledge frame (Outline), a pivot base (Cruz) or a frame on castors (Twist), there's even a height adjustable version (Flex).

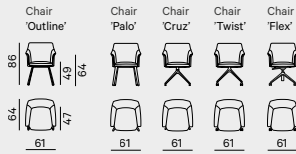

Mime

Inspiration – p. 126

Design: Gino Carollo, 2019

Designer Gino Carollo provided the Mime dining-room chair with stunning details, such as soft pleats, the accent on the front face of the back and beautiful decorative stitching. Mime is available with and without armrests. Further variation is possible by using different materials for the inside and outside and by combining different bases.

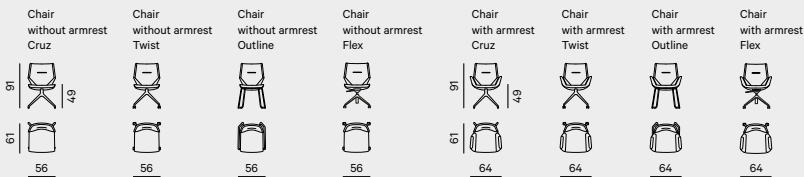

Tamarinde

Inspiration – p. 128

Design: Frans Schrofer, 2013

A slim design with inviting projecting arms and an infinitely variable back that you can adjust to the ideal position after dessert. Depending on the function that you have in mind for Tamarinde, you could go for swivel castors or legs in aluminium, lacquer or epoxy. Whatever you choose, you'll enjoy endless comfort, ensuring that good after-dinner conversations simply go on for hours.



Vynn

Inspiration – p. 130

Design: Christian Werner, 2025

For those who prefer the comfort of an armchair at the dining table, Vynn from Leolux is the perfect choice. This dining chair molds to your body like a glove, making dining and post-meal relaxation truly enjoyable. The decorative stitching under the backrest adds a refined touch, while the small castors make the Vynn chair easy to move. Alternatively, black legs are available.



BRAM

Inspiration – p. 136

Design: Bram Vanderbeke, 2023

The Leolux Viewpoint Collection is an exploration of new design territory. For example the BRAM Alu Stool, a thoroughly intriguing collaborative project with the artist and designer Bram Vanderbeke, examines the possibilities of cast aluminium.

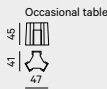

Canopy

Inspiration – p. 138

Design: Studio Truly Truly, 2025

The Canopy coffee table series offers both beauty and practicality. With varying sizes and heights, these tables overlap like treetops in a forest, maximizing space when not in use but offering ample surface area when needed. The asymmetrical shapes of the oak, lacquer, or ceramic table tops complement the gently rounded forms of the Foliage rug by the same designers.

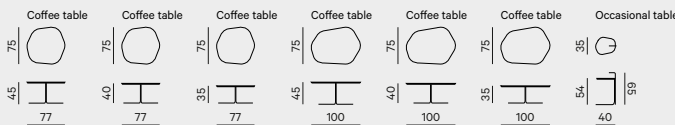

Dice

Inspiration – p. 140

Design: Studio Truly Truly, 2022

Dice stands on an expertly crafted base. Three sets of two legs interweave intriguingly, resulting in an unparalleled expression. Dice's table-top is made of thermally hardened safety glass no less than 15 mm thick. High-quality and imposing at the same time.

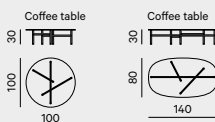

Elli

Inspiration – p. 142

Design: Hanne Willmann, 2023

Looking for a gorgeous low coffee table to match a laid-back lounge interior? Elli is the perfect choice, beautifully crafted from high-quality oak. Elli may be only 26 centimetres high, but it makes a big impact. The table is a stunning example of expert craftsmanship.

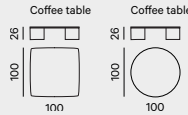

Klaar

Inspiration – p. 144

Design: Studio Truly Truly, 2020

The glass occasional table, Klaar, is a collaboration between Leolux, designers Studio Truly Truly and the Dutch Glass Museum in Leerdam. Every table is an object in itself as each table is actually blown by hand. The colour schemes (Nougat, Lapis and Mottle) are fixed but the patina of the colours is unique for each table.

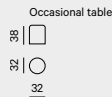

Lapis



Mottle



Nougat

Liliom

Inspiration – p. 146

Design: Norbert Beck, 2010

Organically designed tables in various shapes and heights. Stack them over each other for a neat look. For a natural accent, select a solid walnut or oak table top. A lacquer finish gives you the option of colour. But Liliom goes even further, because you could also have a practical and truly stylish ceramic table top. A beautiful frame in chrome, epoxy or lacquer enables you to create timeless combinations.

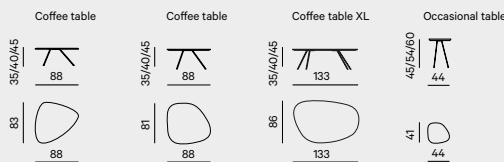

Nunos

Inspiration – p. 148

Design: Hanne Willmann, 2022

Natural materials and high-quality craftsmanship are a source of inspiration for designers. Nunos by Leolux is a striking example of this. Hanne Willmann created a table design that is both ingenious and beautiful, with slimline wooden sections fitting together like puzzle pieces, creating a table top that doesn't simply rest on the base, but forms a harmonious ensemble with it. Sections of the wings appear as subtle details on the table top, emphasising the amazing craftsmanship of our Leolux carpenters.

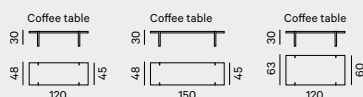

Portello

Inspiration – p. 150

Design: Patrick Belli, 2013

Portello is light, refined and incredibly practical. The table is completely in balance if you lift it using the grip that is hidden on the bottom of the table top. That table top also fits perfectly above the seat of your Leolux sofa, so you have everything within easy reach, from remote control to cup of tea. The leaves are finished in lacquer, in solid oak or in solid walnut and the frame in aluminium, lacquer or epoxy.

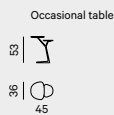

Prismo

Inspiration – p. 152

Design: Edward van Vliet, 2017

The extensive Prismo table series was designed by Edward van Vliet and is all about the interplay between square and circle-shaped leaves and bases. If the table top is square, the frame is circular and vice versa. You can experience this effect to the full in the glass leaves, but this is also a stylish feature in the Prismo ceramic table top. Timeless design for interiors created with love and the utmost care.

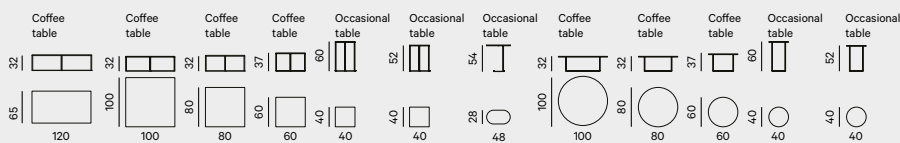

Tampa

Inspiration – p. 154

Design: Beck Design, 2019

The Tampa tables combine their useful function and colourful look with a playful shape. Stunning compositions can be created by combining various leaf shapes. Tampa is available in a beautiful fixed version with a round, bean-shaped or oval table top. The materials also differ per version, from oak or walnut to ceramic, glass or lacquer.

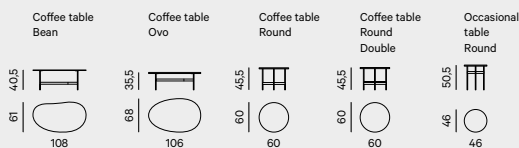

Toveri

Inspiration – p. 156

Design: Studio Truly Truly, 2021

Toveri combines gentle curves and hard materials. The designers have created a table series with gentle forms and striking features. They have moved the connection between the table top and the base plate to the centre of the tables, so the table top appears to float. The symmetry of both sections suggests that the base plate is a shadow of the table top. Studio Truly Truly designed a complete series of Toveri tables in various materials, heights and dimensions.

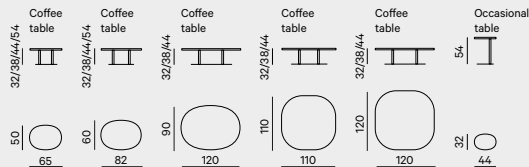

Bondi

Inspiration – p. 158

Design: A Design Studio, 2019

This table adds a wealth of colour to every interior. Bondi's unusual organic wing shape is the first thing you notice. This creates space for at least five users. The three-leg steel frame offers stability and the table top gives Bondi character in oak, walnut or ceramic.

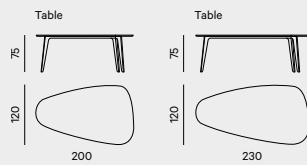

Columna

Inspiration – p. 160

Design: Hugo de Ruiter, 2016

Columna by Leolux is a very practical table. Round or oval, to ensure that it offers space for the maximum number of guests, without awkward table legs. The table top is available in solid walnut or oak, ceramic or lacquer. A beautiful detail of this subtle table is the way in which the column connects to the leg: like an ancient marble column, smooth or fluted. Columna is also available in XL-versions that have two columns.

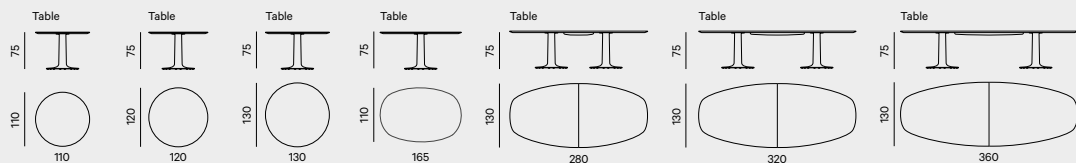

Conka

Inspiration – p. 162

Design: Studio kaschkasch, 2025

Conka by studio kaschkasch is a striking round table that combines practicality with visual appeal. Its solid wood or ceramic tabletop is eye-catching, complemented by a unique diamond-shaped column base, elegantly wrapped in leather. Perfect for hosting guests, Conka adds a distinctive touch to any dining space.

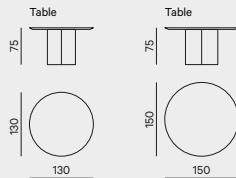

Taival

Inspiration – p. 164

Design: Studio Truly Truly, 2024

Taival is available in several fixed sizes, from a compact square table to a large rectangular variant. Each size has the same beautiful rounded corners, creating a soft look. The table top is available in three materials: oak veneer, walnut veneer and lacquer. For the colour of the base, you can choose between different colours of powder coating or lacquer.

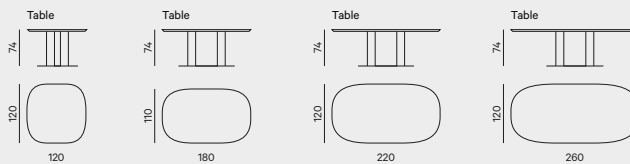

Tico

Inspiration – p. 166

Design: Beck Design, 2021

The versatility of the Tico dining-room table is already apparent from the dimensions; it is available in three widths and in no fewer than eight lengths from 140 to 280 cm. The corners and elegant aluminium legs are curved as standard and bend seamlessly with the curve of the table top. A wide range of materials and colours is available for an individual finish, each with its own look; each version is different in solid walnut and oak and ceramic, making Tico a serious candidate for many interiors.

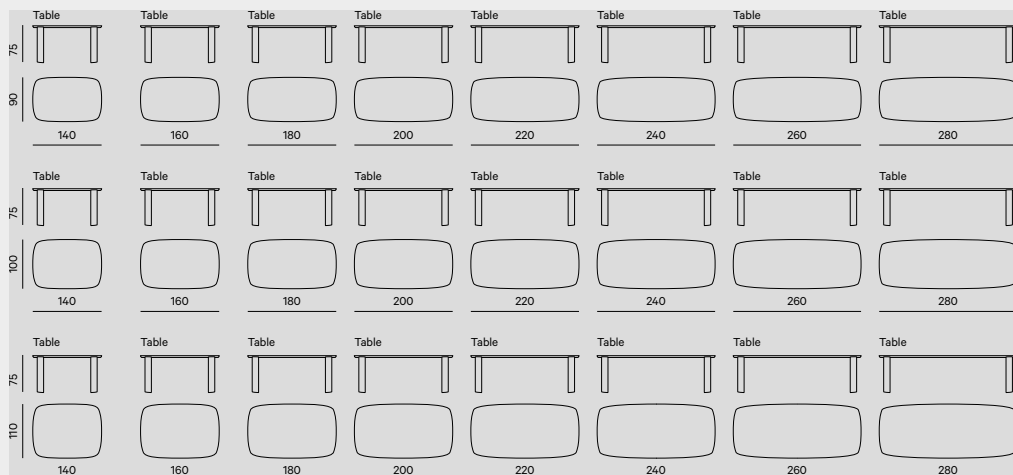

Toveri Dining

Inspiration – p. 168

Design: Studio Truly Truly, 2022

Studio Truly Truly designed a luxury dining table to match the Toveri tables. In line with the coffee tables, the Toveri dining table is an interplay of soft shapes and hard materials, of shadows and curves. A generous table top in solid wood or chic Ceramic rests on a steel base plate and two flattened supports. Timeless or contemporary. Toveri is also available in lacquer finishes for colour enthusiasts.

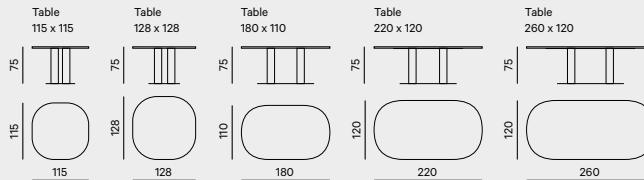

Cosy Cushions

Inspiration – p. 174

Design: Studio KZ15, 2013

Leolux developed an extremely complete cushion collection for that perfect look. Customised, available in nine dimensions, in any type of Leolux upholstery fabric and with a choice of no fewer than six finishes. So why would you select cushions off the shelf? The 'Pure' padding contains a combination of foam and small feathers. The 'Royal' padding is foam and is also suitable for people with an allergy to down.

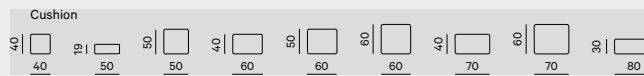

Cushion Lusso

Inspiration – p. 175

Design: Studio KZ15, 2018

Lusso is unique in its decorative value, with the embroidered motif on the front giving the cushion a fun, modern element. You can totally personalise Lusso when you choose the materials and the colours from the Leolux collection: fabric or leather on the front, fabric on the back. For wonderfully soft comfort, we fill your cushion with duck feathers, which we combine with high-quality foam.



Amund

Inspiration – p. 176

Design: Maghalie Doods, 2020

The Amund rug is a very soft rug that feels comfortable to the feet. It is available in three sizes: two rectangular ones (200 x 300 cm and 240 x 340 cm) and a round version with a diameter of 280 cm. All three sizes of this rug are available in five different natural colours.



Bear



Reindeer



Seal



Husky

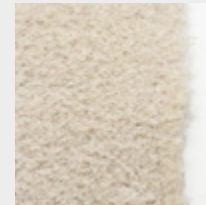

Polar Fox

Foliage

Inspiration – p. 180

Design: Studio Truly Truly, 2025

Inspired by the changing colors of leaves and the shifting shadows on the forest floor, Foliage by Studio Truly Truly features carefully selected yarn colors and intricate patterns. These combine with the subtle stripes of the wool area rug, drawing directly from nature's beauty.

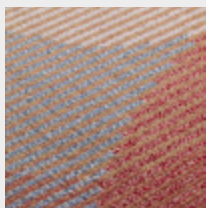
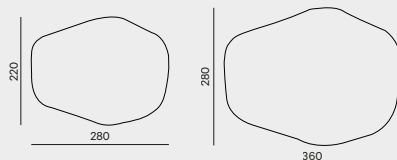

Boreal

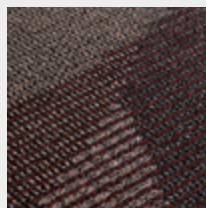

Maquis

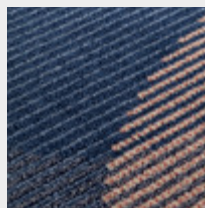

Primas

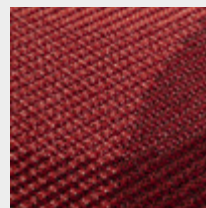

Temperate

Patio

Inspiration – p. 182

Design: Studioepe, 2023.

This spectacular rug, designed by Studioepe in Milan, is a visual interplay of overlapping surfaces in which colours and patterns enhance one another to dramatic effect.

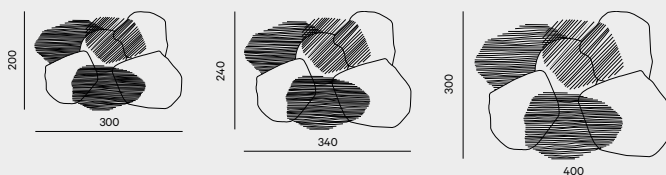

Patna

Inspiration – p. 184

Design: Leolux, 2018.

The Leolux rug collection offers various size, colour and pattern options. A really beautiful choice is the Patna rug. A beautiful hand-made rug, in six warm colours, with an accent colour that is incorporated in little loops throughout the rug. Patna is manufactured entirely from viscose, which provides a stunning sheen.

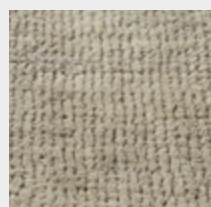
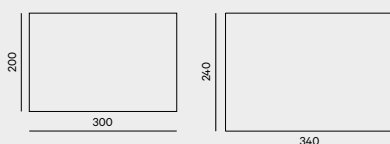

12 Chalk

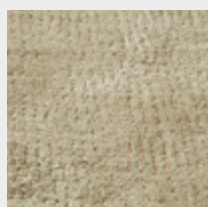

13 Beige

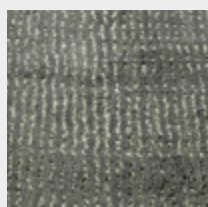

22 Light Grey

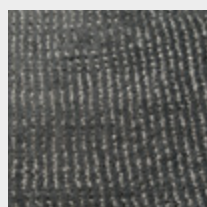

23 Grey

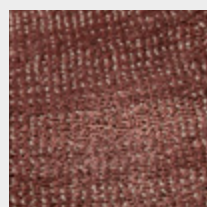

44 Burgundy

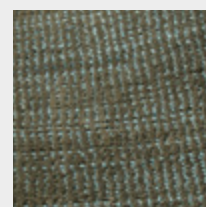

53 Taupe

Valleys

Inspiration – p. 186

Design: Studio Truly Truly, 2023.

Look closely at the little valleys, and you'll see that the pile has been subtly cut away in a step pattern, just as a river patiently creates a valley. The Valleys rug is available only in grey or ivory, and this monochromatic approach makes the layered structure all the more appealing.

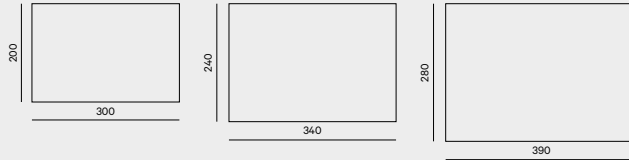

Grey

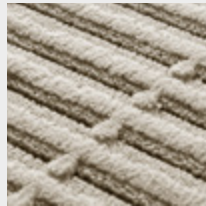

Ivory

Amulet

Inspiration – p. 229

Design: Edward van Vliet, 2017

Edward van Vliet's Amulet series: eye-catching because of its shape and proportions, and practical in daily use. There are two types (I and II). Both have a sloping base, but one of the two also sees these facets carried through to the top. The octagonal footstool offers an extra place to sit, but is also very handy as a side table due to its sturdy, flat seat.

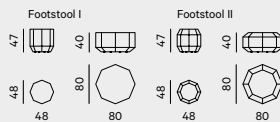

Bolmin

Inspiration – p. 178

Design: Studio Truly Truly, 2025

Bolmin by Studio Truly Truly plays with color and texture in a series of three round footstools. Each stool features two distinctive designs: large decorative seams and oversized piping. The contrasting colors and materials create striking accents, while subtle combinations allow for endless possibilities.

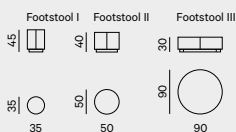

Every Leolux product is manufactured entirely from high-quality materials. Each contributes to the quality, feel and look of your new Leolux. Of course, the upholstery plays an important role in upholstered furniture, but that's not the only important feature. You also have a huge choice of wood, lacquer, marble and much more. That's why we're itemising the many beautiful materials from our collection in these pages.

Materials

Leather

At Leolux, we are fervent admirers of leather as an upholstery material. Because whoever chooses leather chooses character. Leather is a natural product, and it exudes the quality that we feel so strongly about. Each type of leather has its own specific features and properties, such as the type of finish, feel and type of use. That is why we would like to explain about the various leather types.

Ceras

Ceras is a soft grain leather with brilliant colours that is nevertheless very suitable for daily use. The surface area is lightly polished, so the original structure of the hide is preserved. A perfect choice for lovers of leather with a luxurious touch.

Finish: semi-aniline
Emotion: pure nature, rich and luxurious
Type of use: normal
Thickness: 1.2 – 1.4 mm



1090 Flint

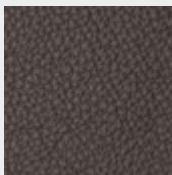

2210 Earth

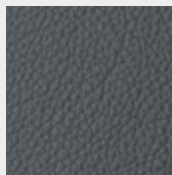

3190 Dew

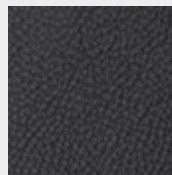

1100 Peat

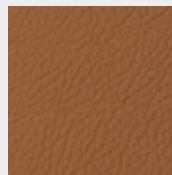

2510 Brandy

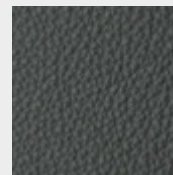

1130 Rock

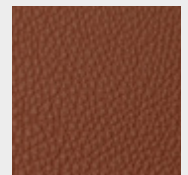

2620 Auburn

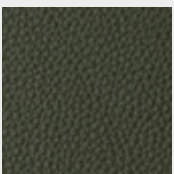

4210 Leaf

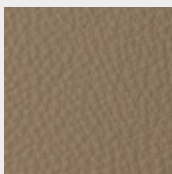

9220 Shell

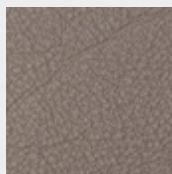

2110 Brindle



9910 Pristine

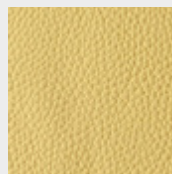

9820 Marl

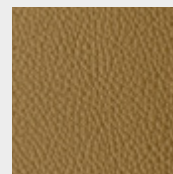

8290 Argile



3910 Steam

Danza

Leolux Danza is pure aniline leather that proudly displays the marks of authenticity and nature's colour variations. The lightly roughened surface and the oiled finish make this leather supremely supple and soft. Danza develops a beautiful patina in the course of time.

Finish: aniline
Emotion: natural, soft and vintage
Type of use: elegant
Thickness: 1.1 – 1.3 mm

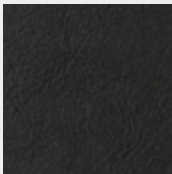

100 Phantom

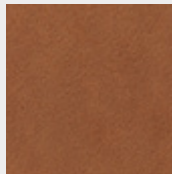

268 Mocha

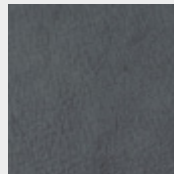

315 Mirage

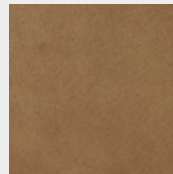

209 Moreno

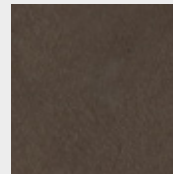

270 Bombay

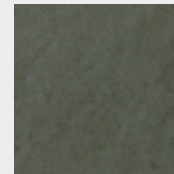

410 Olive

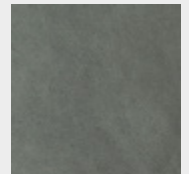

910 Slate

Negev

This aniline leather proudly displays its origin and radiates strength and authenticity. Visual deviations in the hide, such as structural differences and skin folds, are deliberately integrated into the leather rather than removed by Leolux's leather specialists.

Finish: smoothed aniline
Emotion: rugged and generous, with a luxurious feel
Type of use: elegant
Thickness: 2.1 – 2.4 mm

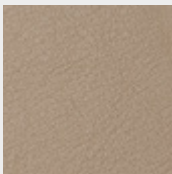

920 Seco

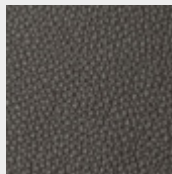

210 Nervio

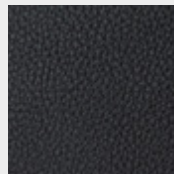

100 Noche



226 Duna



269 Arena

Noli

Noli is a naturally pure leather with an exclusive full-grain quality and a buffed aniline finish. It is finished with a custom-designed Leolux finish. This enables Noli leather to retain its silky grain feeling and a transparent depth.

Finish: smoothed aniline
Emotion: a natural, silky feeling
Type of use: elegant
Thickness: 1.4 – 1.6 mm

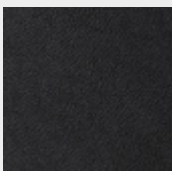

100 Carbone

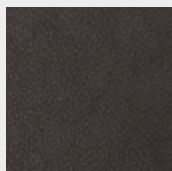

210 Ramo

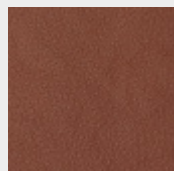

620 Moka

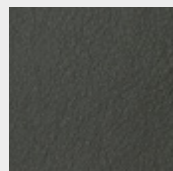

190 Argento

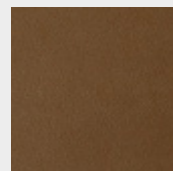

272 Oliva

Raffino

Raffino has the soft grip that is so characteristic of authentic natural leather. It has the hallmarks of real leather that the thin protective layer cannot hide. This layer ensures that Raffino is more resistant to dirt, but it still needs to be treated with care during everyday use.

Finish: smoothed aniline
Emotion: pure and luxurious natural leather
Type of use: elegant
Thickness: 1.4 – 1.6 mm

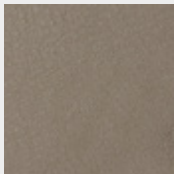

290 Koala

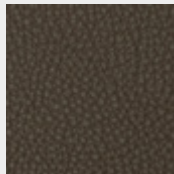

200 Mink

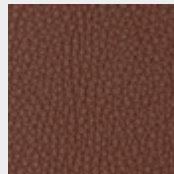

266 Kodiak

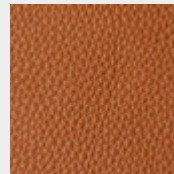

720 Fox

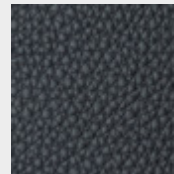

130 Dragonfly

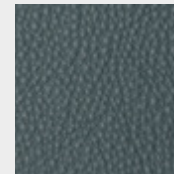

340 Whale

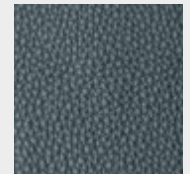

400 Turtle

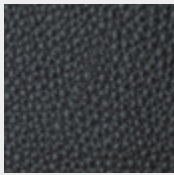

100 Panther



918 Lynx



294 Fennic

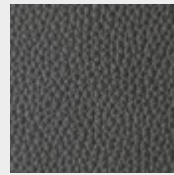

109 Shark

Senso

The high-quality finish provides extra protection against external influences such as light, dirt and dust. The hide thickness and the robust structure of Senso give furniture a special cachet that is admired by all lovers of strong leather qualities.

Finish: pigmented
Emotion: leather with body that is extremely durable
Type of use: intensive
Thickness: 1.4 – 1.7 mm



8100 Amber

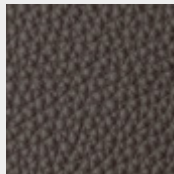

2210 Chocolat



2100 Walnut

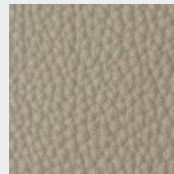

4400 Off-White

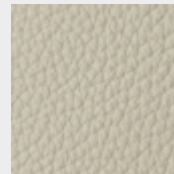

9080 Egret

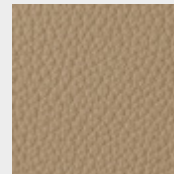

7200 Sahel

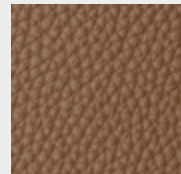

2960 Camel

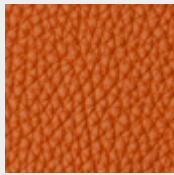

7600 Apricot



6700 Cinnabar



2260 Terracotta

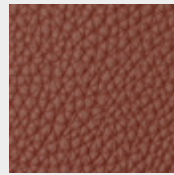

4100 Rust



6900 Blossom



6870 Grenadine

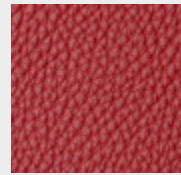

1077 Ferrari



6620 Brick

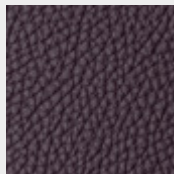

5000 Berry

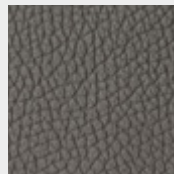

1120 Castor

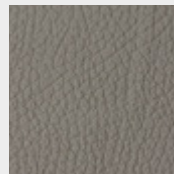

1290 Mist

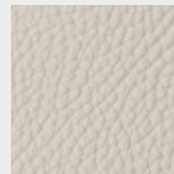

8000 Polar

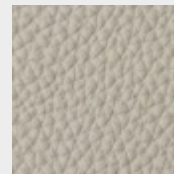

9100 Dawn

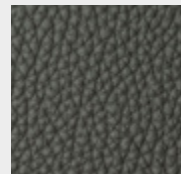

3906 Ombra

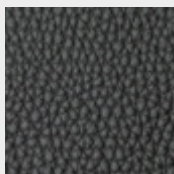

1000 Black



6110 Olivine



4980 Wasabi

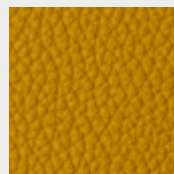

8700 Mimosa



4210 Avocado

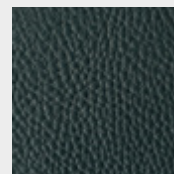

3441 Sagada

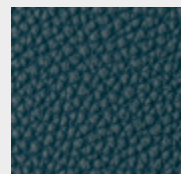

3040 Teal

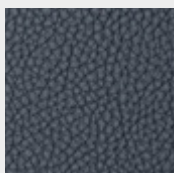

2000 Cobalt

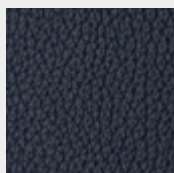

3100 Eclipse

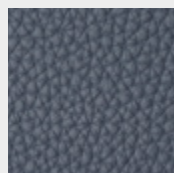

3210 Tempest

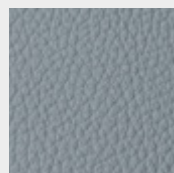

3890 Heaven

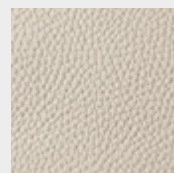

9050 Pampas

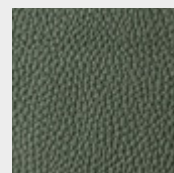

4110 Forest

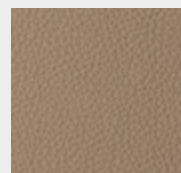

1107 Thunder

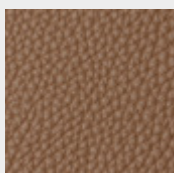

2670 Caramel

Fabric

If you prefer fabric upholstery, Leolux also has a wide range of options. Beautiful woven materials, produced by trusted suppliers such as Kvadrat and De Ploeg. Whatever the feel, colour and type of use, there is a fabric that offers the perfect answer to your requirements and the style you had in mind for your new furniture.

Amelia

Not available in some international markets.

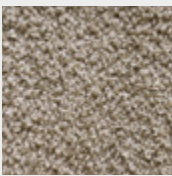

401 Bone



610 Hazelnut

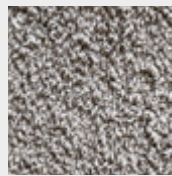

602 Walnut

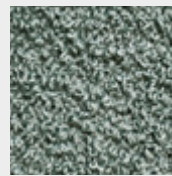

711 Jaidette

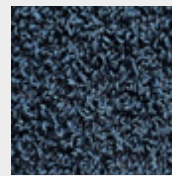

706 Dark Blue

Apollo

Not available in some international markets.

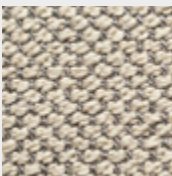

31 Star

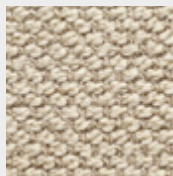

32 Moon

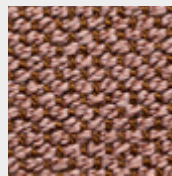

12 Venus

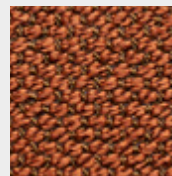

57 Sun

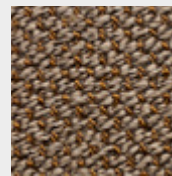

56 Earth

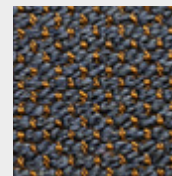

66 Neptune

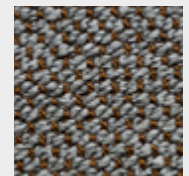

81 Mercury

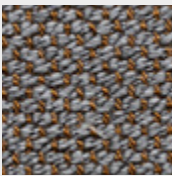

86 Pluto

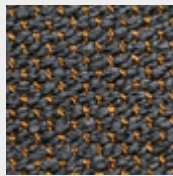

50 Jupiter

Beams

Not available in some international markets.

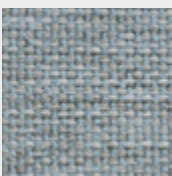

278 Wave

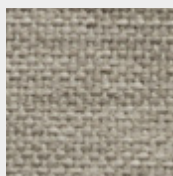

240 Shore



719 Pine



801 Meso

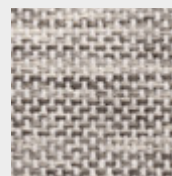

702 Lunar

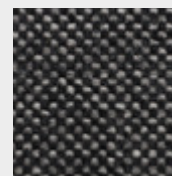

171 Taiga

Essential

Not available in some international markets.

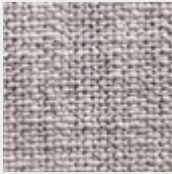

8 Nimbus

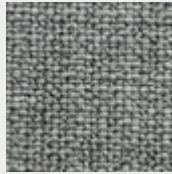

10 Paloma

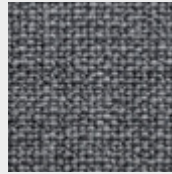

11 Frost

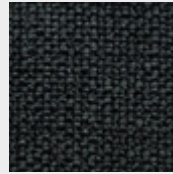

12 Anthracite



26 Egret



2 Peyote



6 Sedona

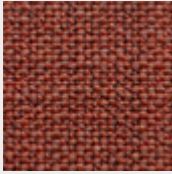

9 Aragon

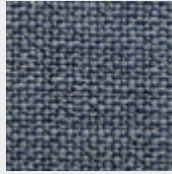

27 Allure

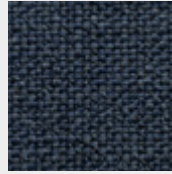

21 Saragosso

Evla



159 Light blue

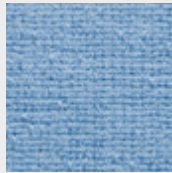

135 Blue

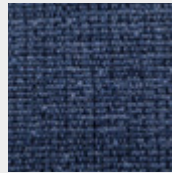

149 Dark blue

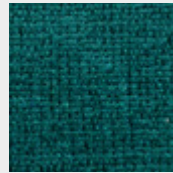

151 Turquoise

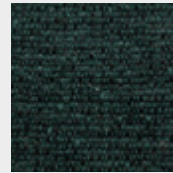

138 Dark green

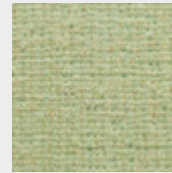

160 Light green

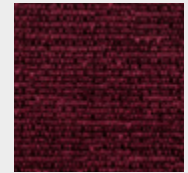

134 Maroon



157 Dark red



136 Red



154 Pink



139 Yellow



153 Camel

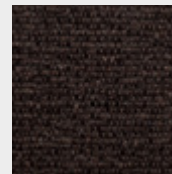

144 Dark brown



021 Anthracite

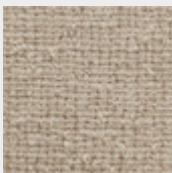

155 Warm grey



142 Grey

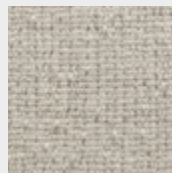

137 Light grey



162 Sand

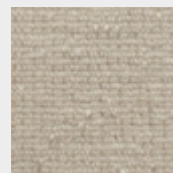

028 White

Loft

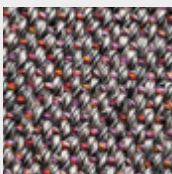

103 Mangistan

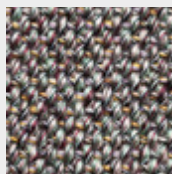

700 Longan

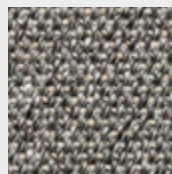

127 Pitaya

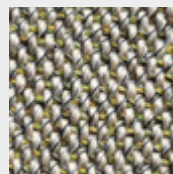

209 Nangka

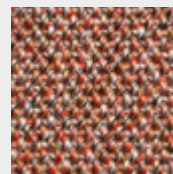

304 Kaki

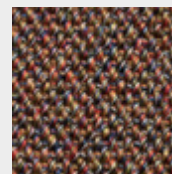

500 Salak

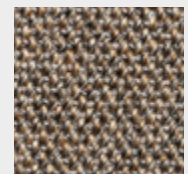

401 Malanga

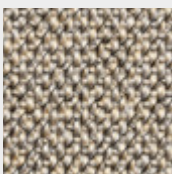

200 Langsat

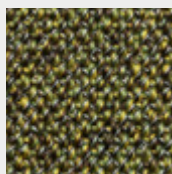

900 Doerian

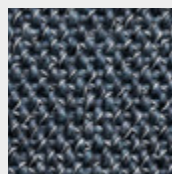

880 Salvia

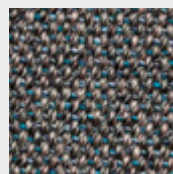

180 Fargesi

Mondo

Not available in some international markets.

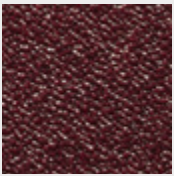

013 Viola

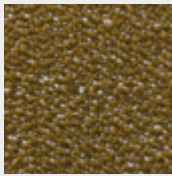

046 Oro

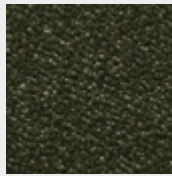

019 Verde

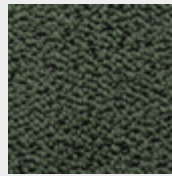

090 Foresta

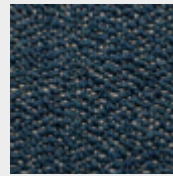

081 Nautica

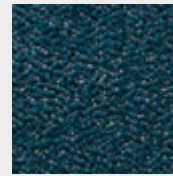

079 Acqua

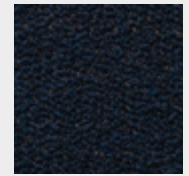

048 Sera

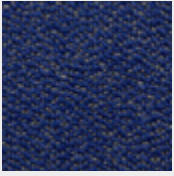

008 Azzuro

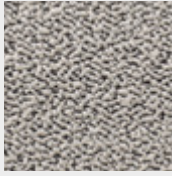

002 Forum

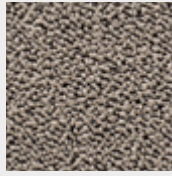

012 Strada



004 Grigia

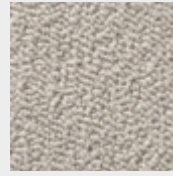

020 Bianco

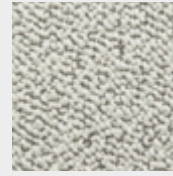

042 Marmo

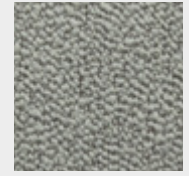

027 Piazza



071 Nero

Prairie



17

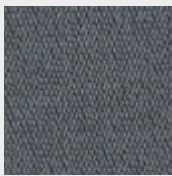

48

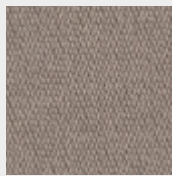

79

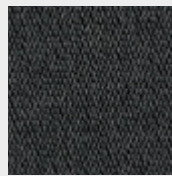

88

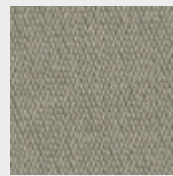

97



45

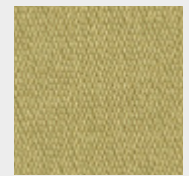

59



86

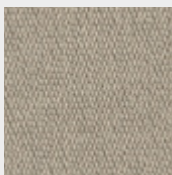

96

Robou



30 Light Grey

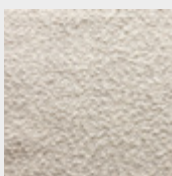

01 White

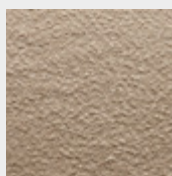

02 Beige

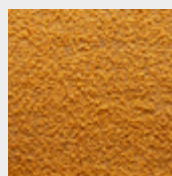

22 Amber

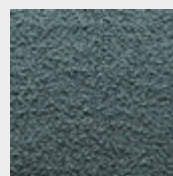

19 Dark Green

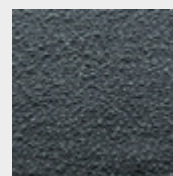

18 Steel Blue

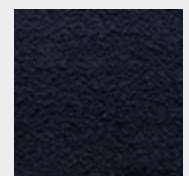

17 Midnight Blue



28 Warm Grey

Sivo

2 Light Grey



3 Beige

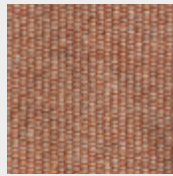

5 Orange



6 Taupe

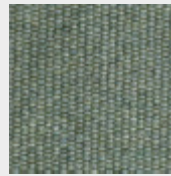

7 Emerald

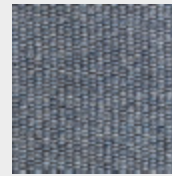

8 Blue

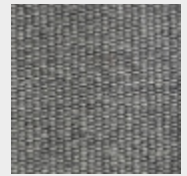

9 Grey



10 Charcoal

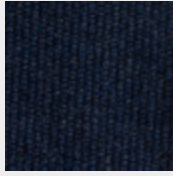

13 Dark Blue

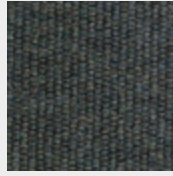

14 Dark Green

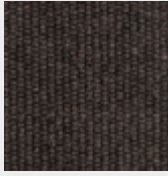

15 Brown

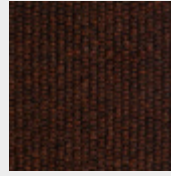

16 Maroon

Sotega (Artificial Leather)

Not available in some international markets.

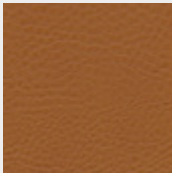

Fuchsgold

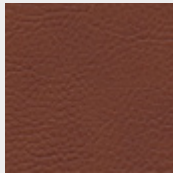

Marone

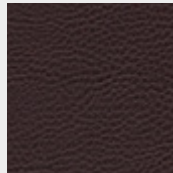

Schoko

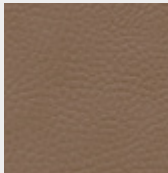

Smoke

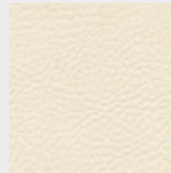

Hellbeige

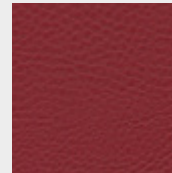

Carmin

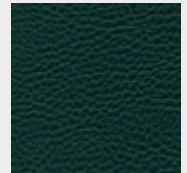

Forest

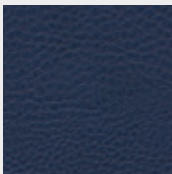

Ocean

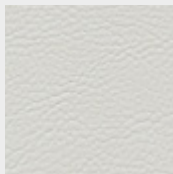

Lichtgrau

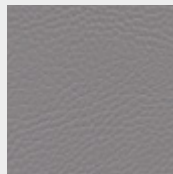

Platin

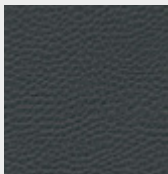

Anthrazit

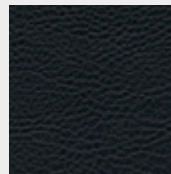

Schwarz

Spazio

Not available in some international markets.

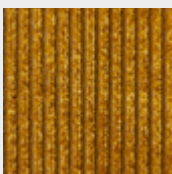

52 Rust



120 Brick

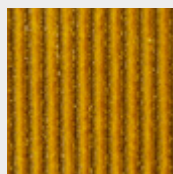

403 Yellow

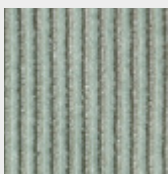

614 Light Blue

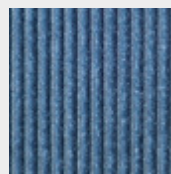

602 Clear Blue

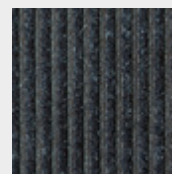

64 Dark Blue

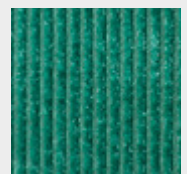

219 Bright Green

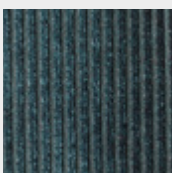

61 Petrol

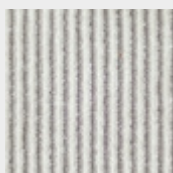

801 Light Grey

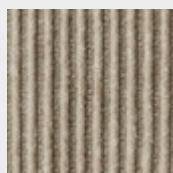

37 Beige

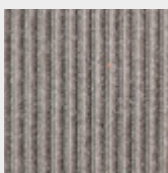

82 Grey

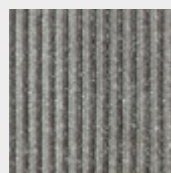

81 Dark Grey

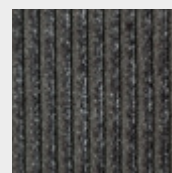

86 Anthracite

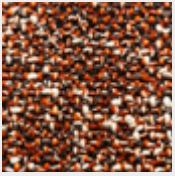
State

030 Terra

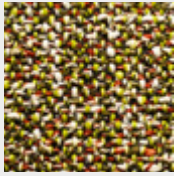

101 Lima

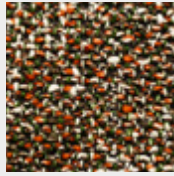

110 Tuscany

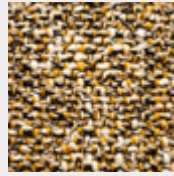

201 June



033 Camo

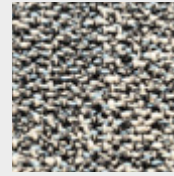

903 Early

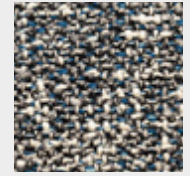

902 Cobalt

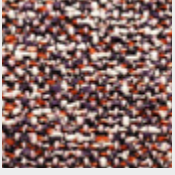

611 Violet

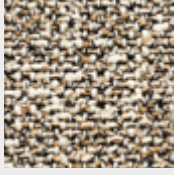

011 Rice

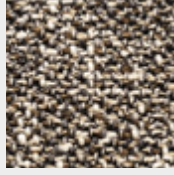

904 Fuse

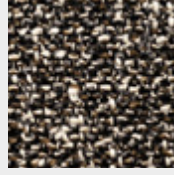

099 Platina

Varese

Not available in some international markets.



5 Blanc



10 Gris



22 Angora

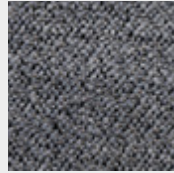

14 Inox



2 Fer



15 Poivre



19 Taupe

Other materials

From a sofa to a coffee table, you can attune your new Leolux product to your taste, down to the very last detail. We offer a huge collection of materials for this so that you can shape your new pride and joy exactly as you'd like. From lacquer to epoxy colours to the most beautiful wood and most exclusive marble.

Ceramic

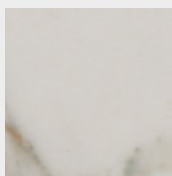

Calacatta

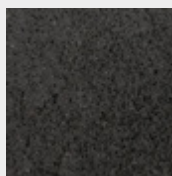

Basalt Noir

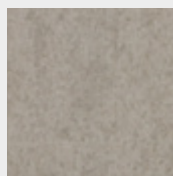

Béton

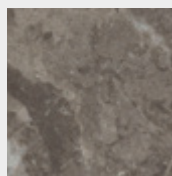

Gris du Gent

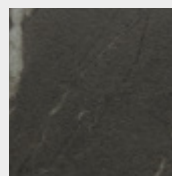

Pietra Grey

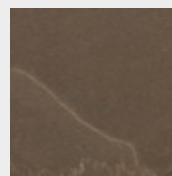

Pulpis

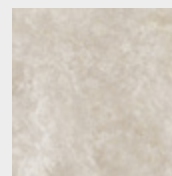

Rapolano

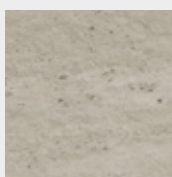

Strata Argentum

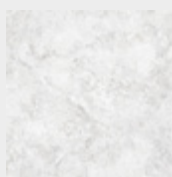

Whitesands

Ceramic Gloss



Capraia

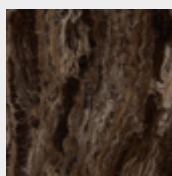

Frappucino

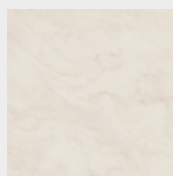

Raffaello

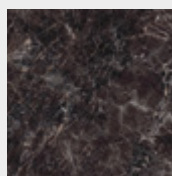

Saint Laurent

Glas

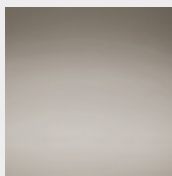

Bronze

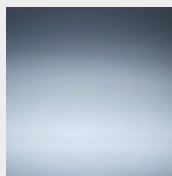

Grey

Wood - oak



Naturel M2100

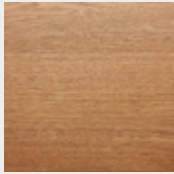

Aged Oak M5700

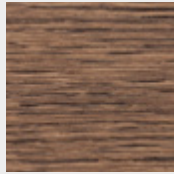

Hazel M5000

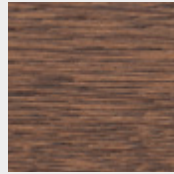

Macademia M3700

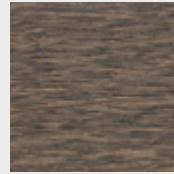

Nut M4100

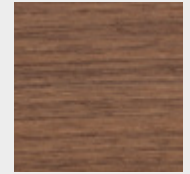

Naturel M2100

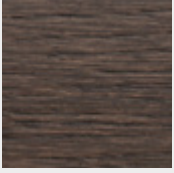

Coffee M4200

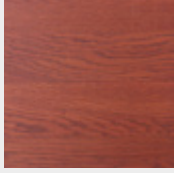

Brick M5600

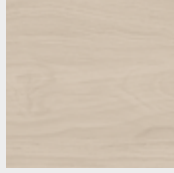

Bright White M5100

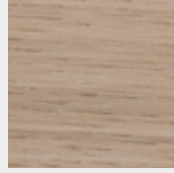

White M4000

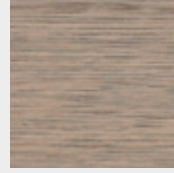

Pistache M4400



Ocean M5800



Pinegrey M4500

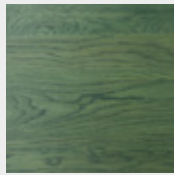

Forest M5500

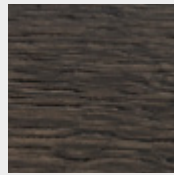

Night M4300

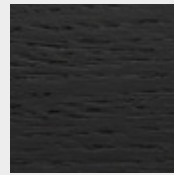

Santos M2900

Epoxy



Lead Diamond

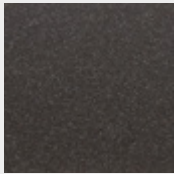

Patina Diamond

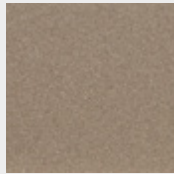

Alpaca Diamond

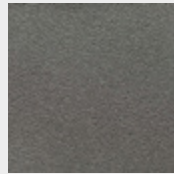

Noctis Diamond

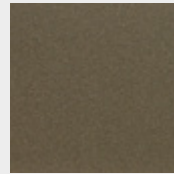

Khaki Diamond

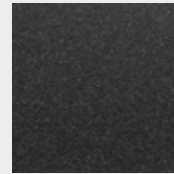

Raven Diamond

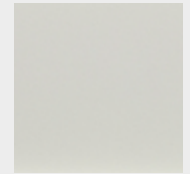

Pearl Matt



Alfalfa Matt

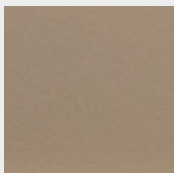

Biscotti Matt

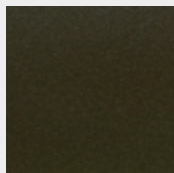

Tungsten Matt

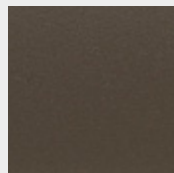

Iridium Matt

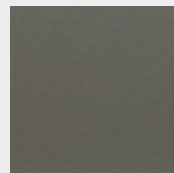

Basalt Matt

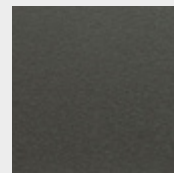

Charcoal Matt

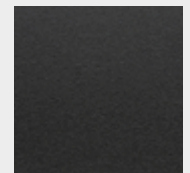

Granite Matt



Ice Silk

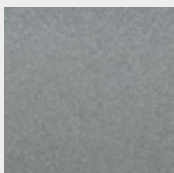

Silver Silk

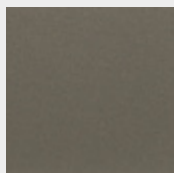

Titanium Silk

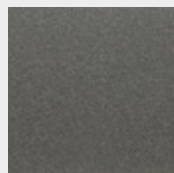

Nickel Silk

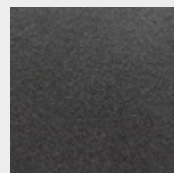

Nuit Silk

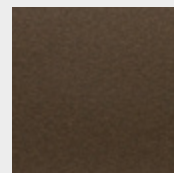

Taupe Silk

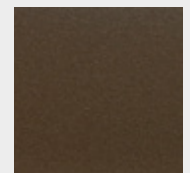

Bronze Silk

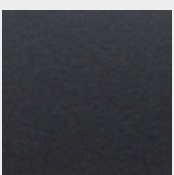

Lava Silk

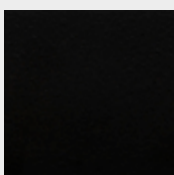

Ebony Silk

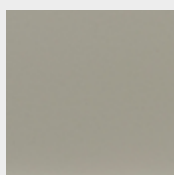

Space Silk

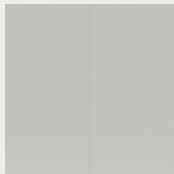
Satine / Spruzza

90 White

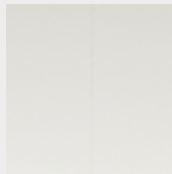

130 Lily

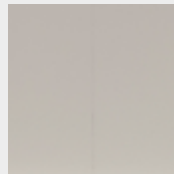

80 Ivory

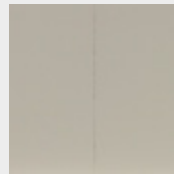

120 Powder

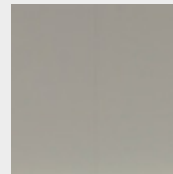

030 Dove

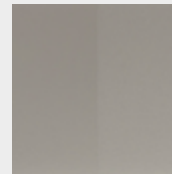

040 Pewter

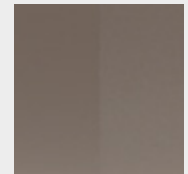

070 Taupe

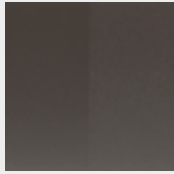

081 Cocoa



210 Carbon

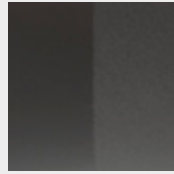

050 Coal

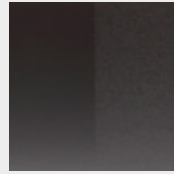

20 Santos

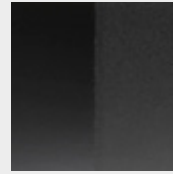

10 Black

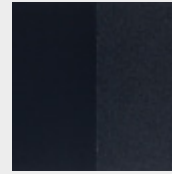

290 Eclipse

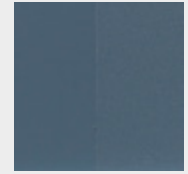

930 Flow

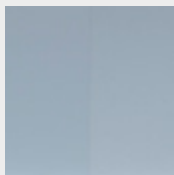

288 Air

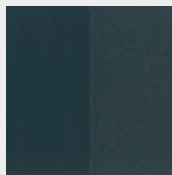

341 Petrol

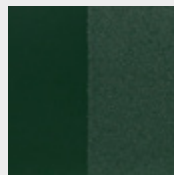

419 Ranger

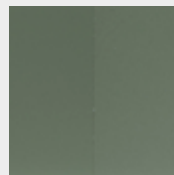

175 Thyme

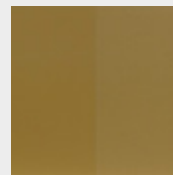

170 Kurkuma

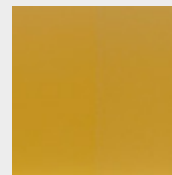

160 Saffron

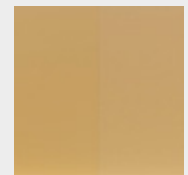

155 Sahara

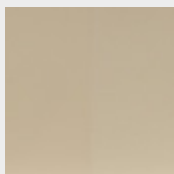

110 Ash

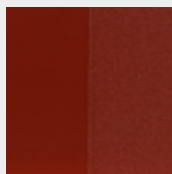

279 Cinnamon



681 Tulip

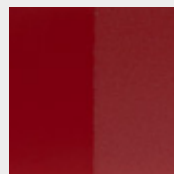

400 Pepper

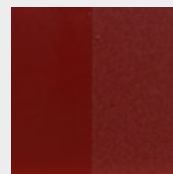

621 Burgundy

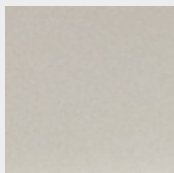
Cristallo

C3100 Eggshell

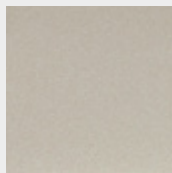

C3000 Vanilla

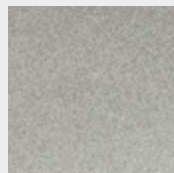

C1100 Platinum

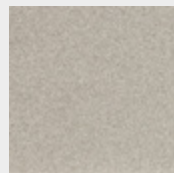

C3500 Pumice

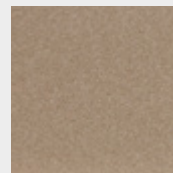

C4300 Alpaca

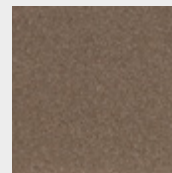

C3600 Champagne

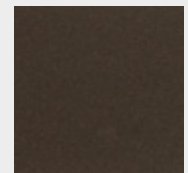

C4400 Taupe

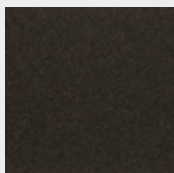

C4600 Notte

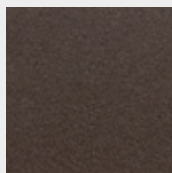

C1000 Dark Chocolate

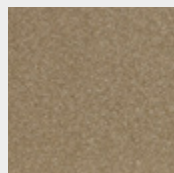

C2900 Gold

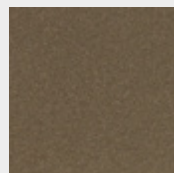

C4500 Bronze

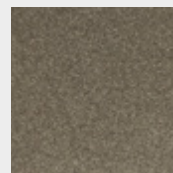

C2800 Military

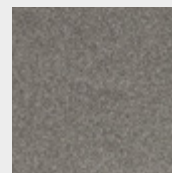

C1200 Steel

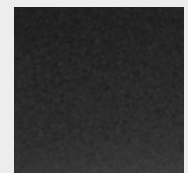

C1300 Raven



Leolux Centers

Experience Leolux in a unique way in our own Leolux Centers. Be welcome in these inspiring showrooms where our advisors can tell you everything about Leolux and the entire collection.

Experience Center Breukelen (NL)

De Corridor 9A
3621 ZA Breukelen
+31 (0)30 293 81 49
experiencecenter@leolux.nl

Design Center Brussel (B)

Bergensesteenweg 423A
1600 Sint-Pieters-Leeuw
+32 (0) 2 331 27 70
info@leolux.be

Design Center Krefeld (D)

Elbestraße 39
47800 Krefeld-Gartenstadt
+49 (0) 2151 94 36 0
krefeld@leolux.de

Follow us on **f** facebook: @leoluxglobal
i instagram: @leoluxdesignfurniture

Art direction:

Studio Truly Truly

Layout:

Jeanic Smits

Text:

Ben Salden | Antal Németh

Chief editors:

Leolux | Studio Truly Truly

Photography:

Pim Top | Zebra Fotostudio's | Yuta Sawamura | Alexander Popelier |
Hugo Thomassen | Chiara Catalini | Peer Coopmans | Fieke Klerkx

Styling:

Karin Kleeven | Eva Reuvers | Studio Truly Truly | Dennis & Did

3D-renderings:

Roel Deden | Andonni Tsoilingkas

We want to thank everyone who has contributed to the creation of
this book.

Leolux Furniture Group

Marinus Dammeweg 55, 5928 PW Venlo, The Netherlands

info@leolux.com

www.leolux.com



**Verband der Deutschen
Polstermöbelindustrie e.V.**

Member of Association of German upholstery manufacturers

© 2025 Leolux. Nothing from this publication may be
copied or reprinted without written permission from
Leolux Furniture Group B.V. Printing and typographical errors
reserved. Colours may vary for typographical reasons.

Leolux is part of the Leolux Furniture Group.

